

COPYRIGHT RESERVED. THIS DRAWING MUST NOT BE SCALED. VARIATIONS AND MODIFICATIONS TO WORK SHOWN ON THESE DRAWINGS SHALL NOT BE CARRIED OUT WITHOUT WRITTEN PERMISSION FROM THE ARCHITECTS. THIS DRAWING IS THE EXCLUSIVE PROPERTY OF ROBERT CICOZZI ARCHITECTURE INC. AND CAN BE REPRODUCED ONLY WITH THEIR WRITTEN PERMISSION.

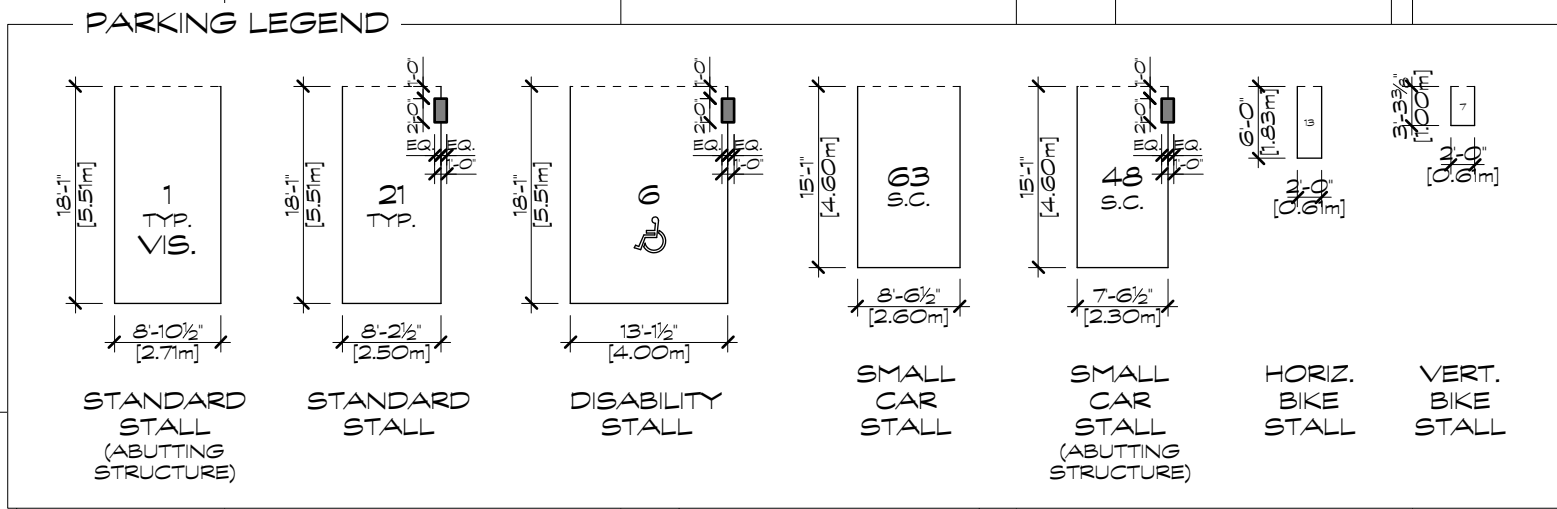
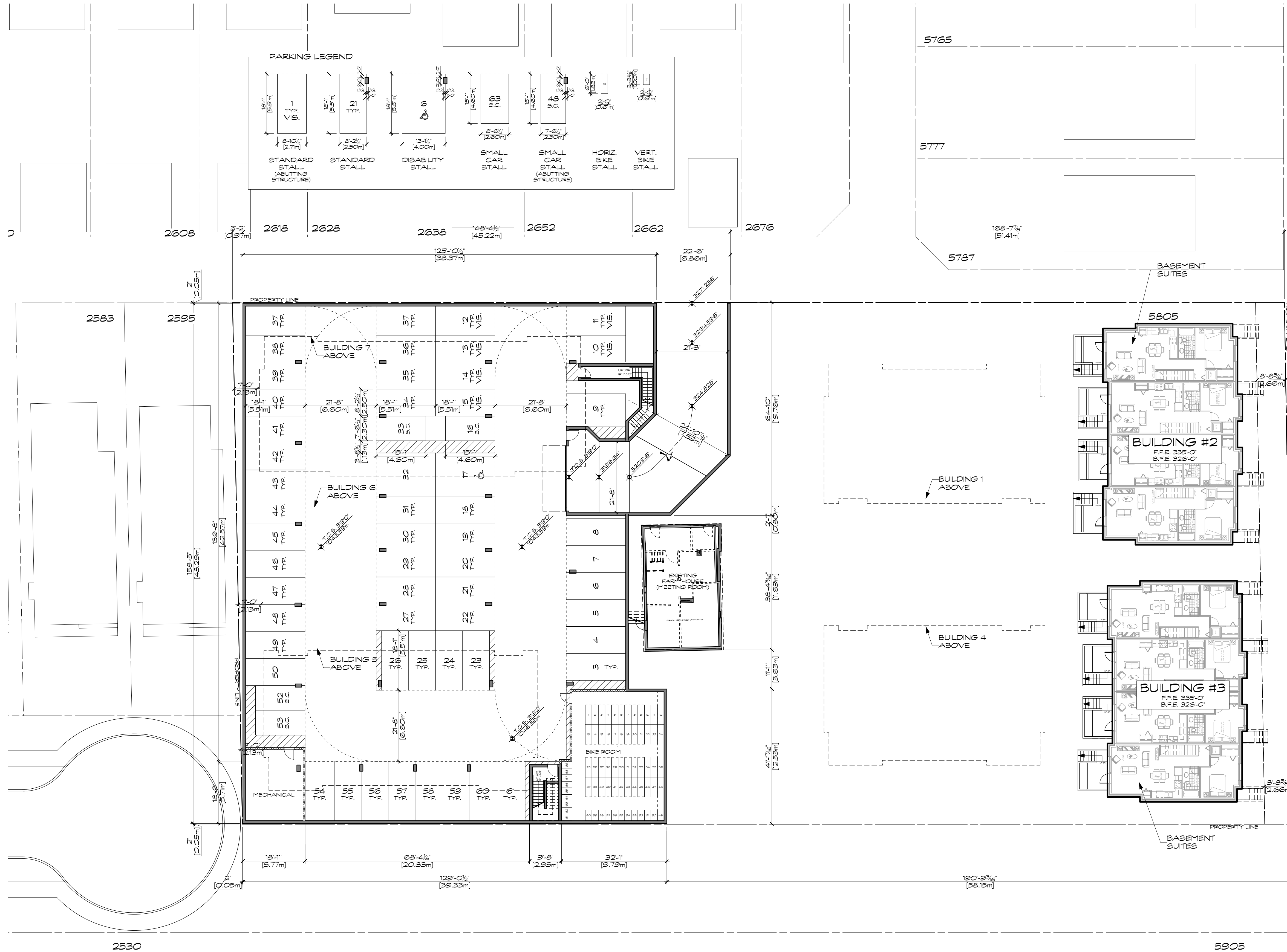

1 PARKING LEVEL PLAN
A1.1 SCALE: 1/8" = 1'-0"

REVISION:

NO.	DATE	DESCRIPTION

ISSUE:

DATE	DESCRIPTION
06.01.14	ISSUED FOR UDP REZONING
03.03.14	COV REVIEW/LANDSCAPE
10.03.14	ISSUED FOR D.P.

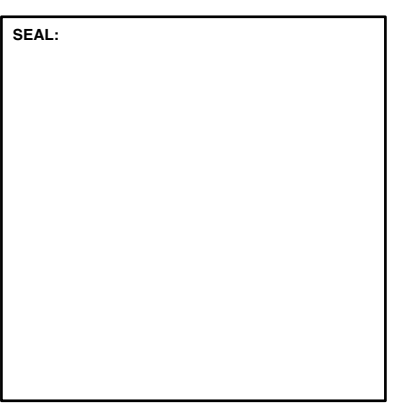

RCA

Robert Ciccozzi Architecture Inc.
200 - 2339 Columbia Street
Vancouver, B.C.
Canada V5Y 3Y3
Tel: (604) 687-4741
Fax: (604) 687-4641
admin@ciccozziarchitecture.com

PROJECT:
AVALON RESIDENTIAL
5805 WALES ST.
VANCOUVER, B.C.

DRAWN: EP	CHECKED BY: RC
SCALE: 1/8" = 1'-0"	PROJECT NO.: RCA302

SHEET TITLE:
PARKADE PLAN

REVISION NO.: -	SHEET NO.: A1.1
-----------------	-----------------

