

1 Section
SCALE: 3/32" = 1'-0"

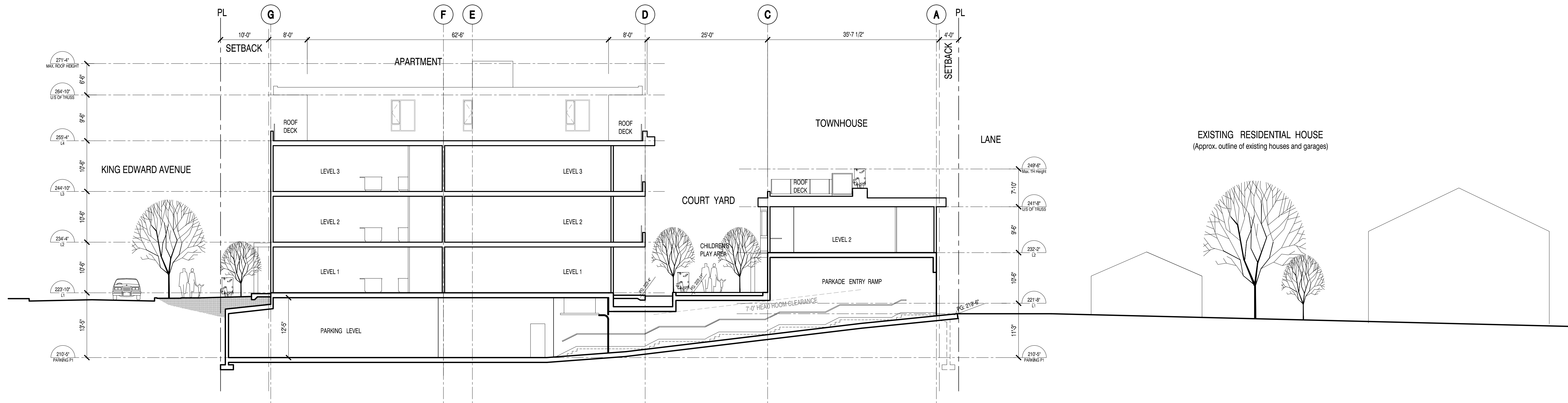

2 Section @ Parkade Entry
SCALE: 3/32" = 1'-0"

CONSULTANTS:

CLIENT:
Pennyfarthing Development Corp.
100 - 1450 Creekside Drive
Vancouver, B.C.
V6J-5B3

PROJECT TITLE:
King Edward Avenue & Yukon Street
357-391 West King Edward Avenue
Vancouver, BC

DRAWING TITLE:
BUILDING SECTION

DRAWING ISSUED FOR:	DATE ISSUED:	BY:
ISSUED FOR REZONING	2014.01.24	JW

STAMP:

DATE:

KEY PLAN:

NORTH ARROW:

DRAWN BY: -
JOB NUMBER: 1313
REVISION NO.: -
SCALE:
FILE NAME: -
SHEET NO.:

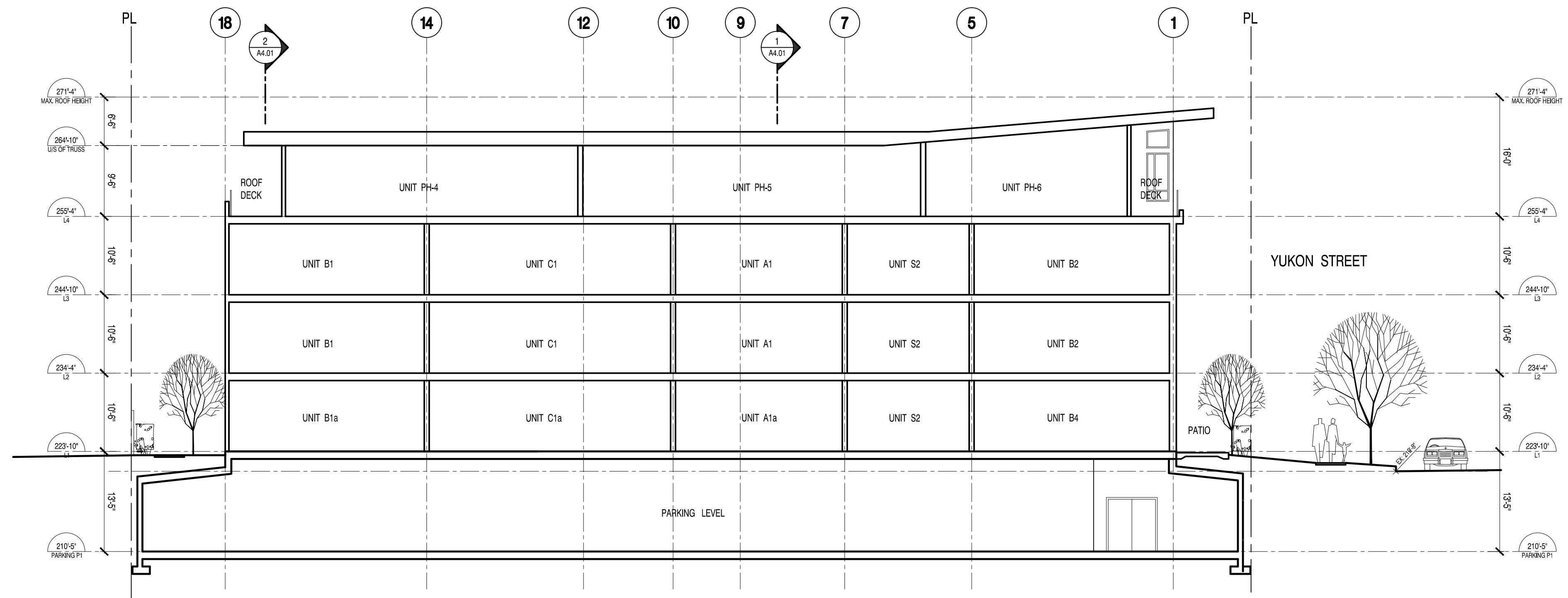

1 Section Through Apartment
SCALE: 3/32" = 1'-0"

CONSULTANTS:

CLIENT:
Pennyfarthing Development Corp.
100 - 1450 Creekside Drive
Vancouver, B.C.
V6J-5B3

PROJECT TITLE:
King Edward Avenue & Yukon Street
357-391 West King Edward Avenue
Vancouver, BC

DRAWING TITLE:
BUILDING SECTION

DRAWING ISSUED FOR: DATE ISSUED BY
ISSUED FOR REZONING 2014.01.24 JW

STAMP:

KEY PLAN:

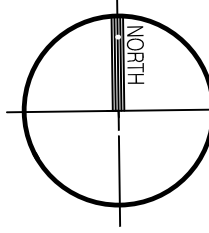
NORTH ARROW:  DRAWN BY: -
JOB NUMBER: 1313
REVISION NO.: -
SCALE: -
FILE NAME: -
SHEET NO.: