

RETAIL PARKING		SIZE
STANDARD	0 SPACES	8'-2.5" x 18'-0"
SMALL	0 SPACES	7'-7" x 15'-1.25"
H/C	0 SPACES	13'-1" x 18'-0"
TOTAL RETAIL		0 SPACES
RESIDENTIAL PARKING		SIZE
STANDARD	35 SPACES	8'-2.5" x 18'-0"
SMALL	8 SPACES	7'-7" x 15'-1.25"
H/C (each space counted as 2)	6 SPACES	13'-1" x 18'-0"
TOTAL RESIDENTIAL		49 SPACES
VISITOR PARKING		SIZE
STANDARD	0 SPACES	8'-2.5" x 18'-0"
SMALL	0 SPACES	7'-7" x 15'-1.25"
H/C	0 SPACES	13'-1" x 18'-0"
TOTAL VISITOR		0 SPACES
TOTALS:		
STANDARD	35 SPACES	8'-2.5" x 18'-0"
SMALL	8 SPACES	7'-7" x 15'-1.25"
H/C	6 SPACES	13'-1" x 18'-0"
TOTAL PARKING PROVIDED:		49 SPACES
ELEC. VEHICLE CHARGING		12 SPACES OF TOTAL

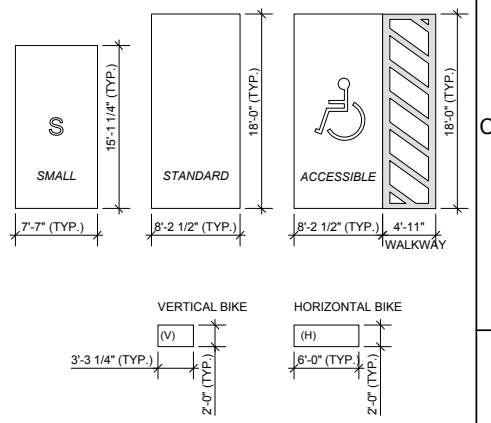

NO.	DATE	ISSUE

Copyright. All rights reserved. Reproduction in whole or in part is prohibited. This drawing as an instrument of service is the property of the architect and may not be used in any way without the written permission of this office.

PROJECT
 Mixed use development
 at 3063-3091, W. Broadway
 City of Vancouver, B.C.

2386 oak street, vancouver, b.c.
 VBH 4J1 tel: 604-731-1127 fax: 604-731-1327

DRAWING TITLE
 U/G parking - P2



U/G 2 PARKING PLAN

SCALE: 1/8" = 1'-0"

SCALE	1/8" = 1'	SHEET NO.	A2.P2
DATE	15/01/20	DRAWN	PS
CHECKED		PROJ. NO.	1409

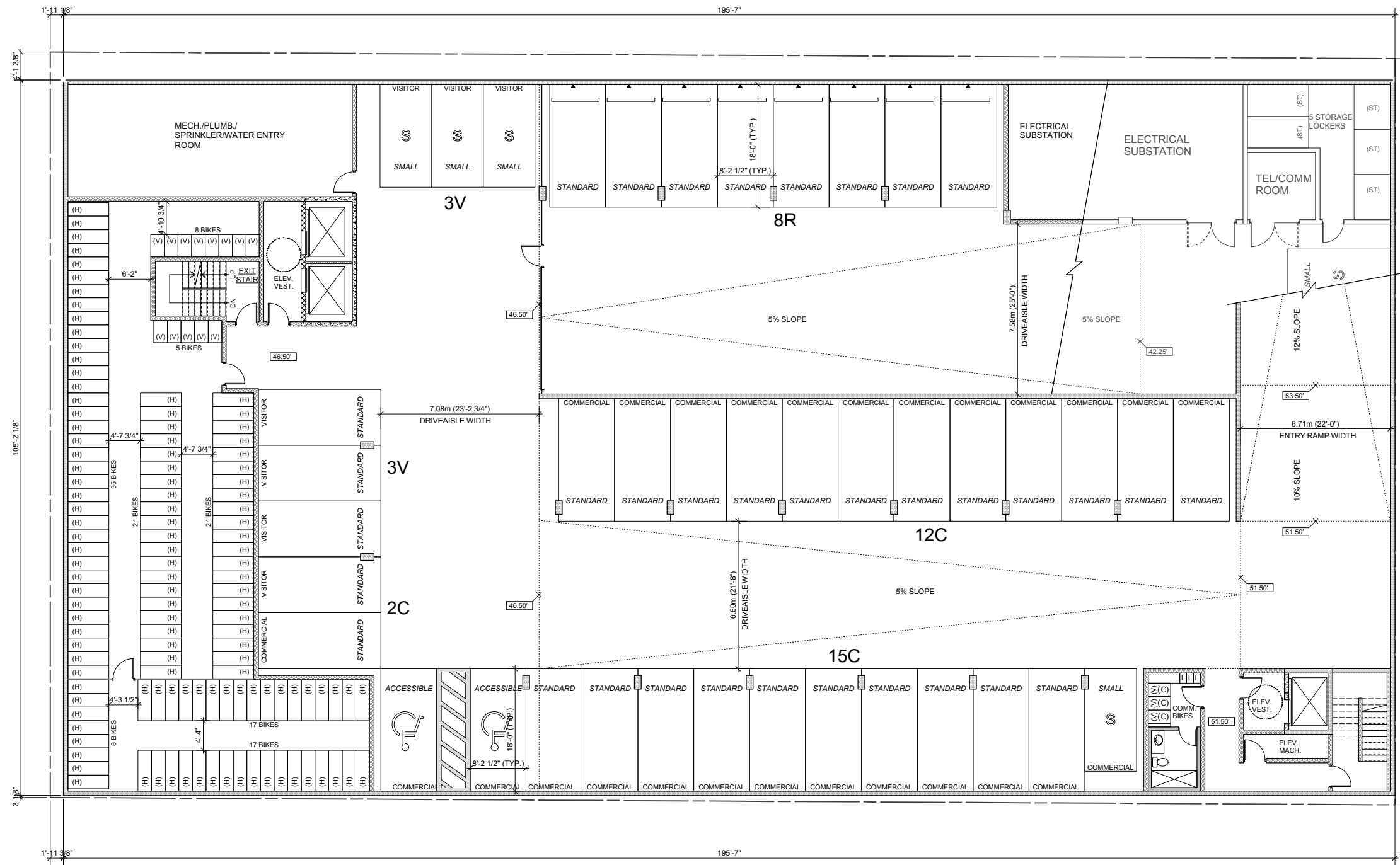

RETAIL PARKING		
	SIZE	
STANDARD	24 SPACES	8'-2.5" x 18'-0"
SMALL	1 SPACES	7'-7" x 15'-1.25"
H/C (each space counted as 2)	4 SPACES	13'-1" x 18'-0"
TOTAL RETAIL	29 SPACES	
RESIDENTIAL PARKING		
STANDARD	8 SPACES	8'-2.5" x 18'-0"
SMALL	0 SPACES	7'-7" x 15'-1.25"
H/C (each space counted as 2)	0 SPACES	13'-1" x 18'-0"
TOTAL RESIDENTIAL	8 SPACES	
VISITOR PARKING		
STANDARD	3 SPACES	8'-2.5" x 18'-0"
SMALL	3 SPACES	7'-7" x 15'-1.25"
H/C (each space counted as 2)	0 SPACES	13'-1" x 18'-0"
TOTAL VISITOR	6 SPACES	
TOTALS:		
STANDARD	35 SPACES	8'-2.5" x 18'-0"
SMALL	4 SPACES	7'-7" x 15'-1.25"
H/C	4 SPACES	13'-1" x 18'-0"

TOTAL PARKING PROVIDED:	43 SPACES
ELEC. VEHICLE CHARGING	8 SPACES OF TOTAL
RETAIL BIKE SPACES	
LOCKER (VERTICAL)	3 SPACES 3'-3.25" x 2'0"
RESIDENT BIKE SPACES	
HORIZONTAL	119 SPACES 6'-0" x 2'-0"
VERTICAL	13 SPACES 3'-3.25" x 2'0"
LOCKER	0 SPACES 6'-0" x 2'-0"
STACK RACK	0 SPACES
TOTAL RESIDENTS	132 SPACES
TOTAL BIKES PROVIDED	135 SPACES
ELEC. BIKE CHARGING	60 SPACES OF TOTAL

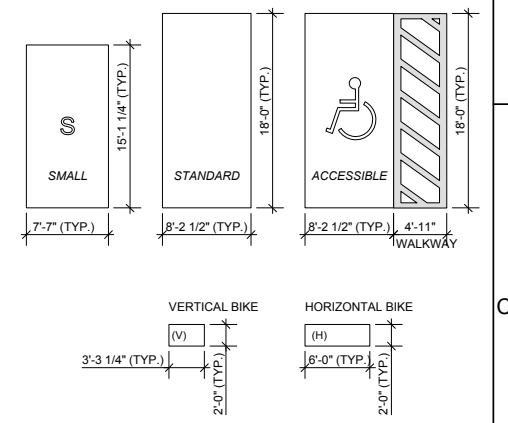

NO.	DATE	ISSUE
Copyright. All rights reserved. Reproduction in whole or in part is prohibited. This drawing is an instrument of service in the property of the architect and may not be used in any way without the written permission of this office.		

PROJECT
 Mixed use development
 at 3063-3091, W. Broadway
 City of Vancouver, B.C.

Yamamoto Architecture Inc.
 2386 oak street, vancouver, b.c.
 V6H 4J1 tel: 604-731-1127 fax: 604-731-1327

DRAWING TITLE
 U/G parking - P1



U/G 1 PARKING PLAN

SCALE: 1/8" = 1'-0"

SCALE	1/8" = 1'	SHEET NO.
DATE	15/01/20	A2.P1
DRAWN	PS	
CHECKED		PROJ. NO. 1409