



2244 - 2280 West 6th Avenue

Rezoning Application
July 7th, 2025





We acknowledge that the land identified in this report is situated on the unceded ancestral territory of the Musqueam, Squamish, and Tsleil-Waututh Nations, and has been stewarded by them since time immemorial.

PROJECT TEAM

OWNER

Asad Hanif
VP Acquisitions
asad.hanif@irent.com

InterRent Real Estate Investment Trust
485 Bank Street, Suite 207
Ottawa, ON
K2P 1Z2

Ian Pinchin
Director, Development
ipinchin@ccclgroup.com

Crestpoint Real Estate Investments Ltd.
130 King St W #1400
Toronto, ON
M5X 1C8

DEVELOPMENT MANAGER

Shad Mayne
Director, Development Manager
Shad.Mayne@colliers.com

Colliers International
1067 West Cordova Street, Suite 1100
Vancouver, BC
V6C 1C7

ARCHITECT

Golnaz Rakhshan
Principal
Golnaz.Rakhshan@Kasian.com

Xueying Xing
Associate, Senior Project Architect
Xueying.Xing@Kasian.com

Kasian Architecture, Interior Design and Planning
1500 West Georgia Street, Suite #1685
Vancouver, BC
V6G 2Z6

CONSULTANTS

Geotechnical Engineer

Geopacific
1779 West 75th Ave
Vancouver, BC
V6P 6P2

Ka Ho Wong, Geotechnical Engineer
Ka.ho.wong@geopacific.ca

Landscape Architect

Perry + Associates
112 E Broadway
Vancouver, BC
V5T 1V9

Johannes Petzel, Principal
jp@perryandassociates.ca

Transportation Engineer

Bunt & Associates Engineering Ltd.
1550-1050 West Pender Street
Vancouver, BC
V6E 3S7

Nicolas Moss, Transportation Engineer
nmoss@bunteng.com

Energy Modeller

Evoke
997 Seymour St Suite #250
Vancouver, BC
V6B 3M1

Alex Blue, Principal & Building
Energy Specialist
ablue@evokebuildings.com

Waste Consultant

Waste Control Services Inc.
51 Glacier Street
Coquitlam, BC
V3K 5Y6

Jeff Nelson, Sales Manager
jeff@wastecontrolservices.com

Land Surveyor

Bennet Land Surveying LTD
275 Fell Avenue Suite #201
North Vancouver, BC
V7P 3R5

John Franko, Vice President
john@bennetsurveys.com

Structural Engineer

Glotman Simpson
1661 5th Ave W
Vancouver, BC
V6J 1N5

Levi Stoelting, Principal
lstoelting@glotmansimpson.com

Arborist

ACL Group
6286 203 Street
Langley, BC
V2Y 3S1

Norman Hol, Principal &
Senior Consultant
norm@aclgroup.ca

Sustainability

Recollective Consulting Inc.
128 W Hastings Street, Suite #210
Vancouver, BC
V6B 1G8

Jason Packer, President
jason@recollective.ca

Elevator Consultant

Gunn Consultants
1020 Mainland St
Vancouver, BC
V6B 2T5

Adam Leung, Project Manager
adam@gunnconsultants.com

Code, Fire / Life Safety & Accessibility

McAuley Consulting
1587 West 8th Ave Suite #503
Vancouver, BC
V6J 1T5

Tavis McAuley, Principal
Jason@recollective.ca

Environmental Engineer

Pinchin
13775 Commerce Parkway, Suite #200
Richmond, BC
V6V 2V4

Jeffrey Armour, Project manager
jarmour@pinchin.com

Mechanical Engineer

Jade West Engineering Co.
15585 24 Ave
Surrey, BC
V4A 2J4

John Makepeace, President
john@jadewest.com

Electrical Engineer

AES Engineering Ltd.
15585 24 Ave
Surrey, BC
V4A 2J4

Sonia Mollaei, Principal
sonia.mollaei@aesengr.com

Market / Interior Design Consultant

Rachel Martinuk Design Consulting
Comox, BC

Rachel Martinuk, Principal
rachel@rm-dc.ca

Civil Engineer

McElhanney
505 Burrard Street, Suite #950
Vancouver, BC
V7X 1M4

Jason Rosevear, Project Engineer
jrosevear@mcelhanney.com

Tenant Engagement / Relocation

Consultant
Sommerville Community Relations

Matthew Thiesen, Managing Partner
matthew@sommerville-cr.com

Thurber Engineering Ltd.

1281 Georgia St W
Vancouver, BC
V6E 3J7

Andrew Sorensen, Review Engineer

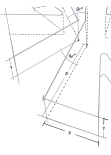

CONTENTS

01 Introduction	05	05 Project Statistics / Data	81
Rezoning Intent	06		
02 Project Context	08	06 Architectural Drawings	84
Context Map	09	Context Map	85
The Site	11	Site Plan	86
		Floor Plans	88
Photos of Site and Existing Streetscape	13	Landscape Drawings	98
		Elevations	103
Zoning Context: Analysis of the Existing Zoning in Surrounding Area	16	Cross-sections	107
		Shadow Studies	110
Policy Context: Analysis of Rezoning-enabling policy, guidelines and bulletins	19	Renders	115
		FSR Overlays	131
03 Rezoning Rationale	38		
Building Height	39		
Site Design	40		
Pedestrian Realm Interface	47		
Livability	50		
Parking and Loading	53		
04 Design Rationale	57		
Indoor and Outdoor Amenity	58		
Residential Dwelling Units	68		
Building Form	71		
Architectural Expression	74		

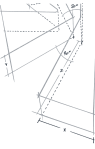



01 INTRODUCTION

01.1 Rezoning Intent

REZONING INTENT

Rezoning Centre, City of Vancouver
Department of Community Services
453 W 12th Avenue
Vancouver, BC V5Y 1V4

Dear All,

On behalf of Crestpoint and InterRent, we are pleased to submit the following Rezoning Application for the proposed residential development at 2244 and 2280 West 6th Avenue in Vancouver.

The application seeks to rezone 2244-2280 West 6th Avenue from RM-4 to a CD-1 Comprehensive Development, to permit the development of two 22-storey towers, complying with the Broadway Plan Kitsilano North – Area B (KKNB -Policy 8.1).

The site is located in Kitsilano on 6th Avenue, bordered by Yew Street and Vine Street. According to the Broadway Plan, the site is part of the KKNB (Kitsilano North - Area B) neighbourhood.

The site is currently developed with two three-storey rental residential buildings, constructed in 1969 and 1970. These existing low-rise apartment buildings contain a total of 89 units, with parking and services accessed via two easements from 6th Avenue.

In line with the objectives outlined in the Broadway Plan, this project aims to facilitate the long-term replacement of the older residential buildings while maintaining existing rental housing affordability levels.

The gross site area is 44,992 square feet (approximately 4,180 square meters). The site is not encumbered by any view cone limitations and is not identified as a site that would have shadowing implications, as it is not in close proximity to public green space.

The proposed rental development includes a total of 416 secured rental residential units, with 40% designated as family-friendly units, exceeding the Housing Mix for Families requirement. This represents a net gain of 327 units, with a minimum of 20% of the 416 residential units offered at below-market rents. The project proposes a total floor area of 27,169 square meters (292,448 square feet) and a density of 6.5 FSR.

The proposed materials included in this rezoning application package are developed in response to the Letter of Enquiry, received on June 21, 2023, from the City of Vancouver.

The development proposes a 6.1-meter (20-foot) lane dedication along the east property line and a 3.1-meter (10-foot) dedication along the south property line.

The proposed redevelopment features family-sized loft units at ground level, single-level apartments in two towers.

Residential amenities will be provided at ground level (including a dog run, fitness centre and multi-sport court), on the lobby rooftop (children's play area and garden), and on the tower rooftops (entertainment lounge, dining area, game lounge, outdoor dining with a BBQ area, outdoor spa, and indoor co-working space). Careful attention has been paid to the massing expression to ensure that each residential unit receives adequate daylight access, particularly in outdoor amenities such as the children's play areas.

Generous patios will be provided for the ground-level loft units and those on the podium roof. Balconies will be included for all one-, two-, and three-bedroom units, as well as studios.



REZONING INTENT

Vehicle parking, mechanical, and electrical rooms will be accommodated on two underground levels, P1 and P2. Bicycle storage, waste management facilities, and supporting bicycle maintenance facilities will be located on the lower mezzanine level, P1.1, which is half above and half below ground. This level will be accessible via two ramps leading to the outdoors.

Two Class B loading positions are proposed adjacent to the side lane and back lane, one for each tower.

The project intends to create a beautiful, warm, and engaging new development that inherently fosters a sense of community while significantly increasing rental housing availability.

We look forward to collaborating with City of Vancouver Planning staff to develop a project that will bring positive benefits to the growing community, providing much-needed homes where there is demonstrated need.

Sincerely,

Kasian Architecture Interior Design and Planning Ltd

Xueying Xing

Senior Project Architect, Associate

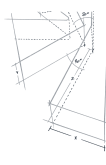

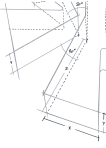

02 PROJECT CONTEXT

02.1 Context Map

CONTEXT MAP

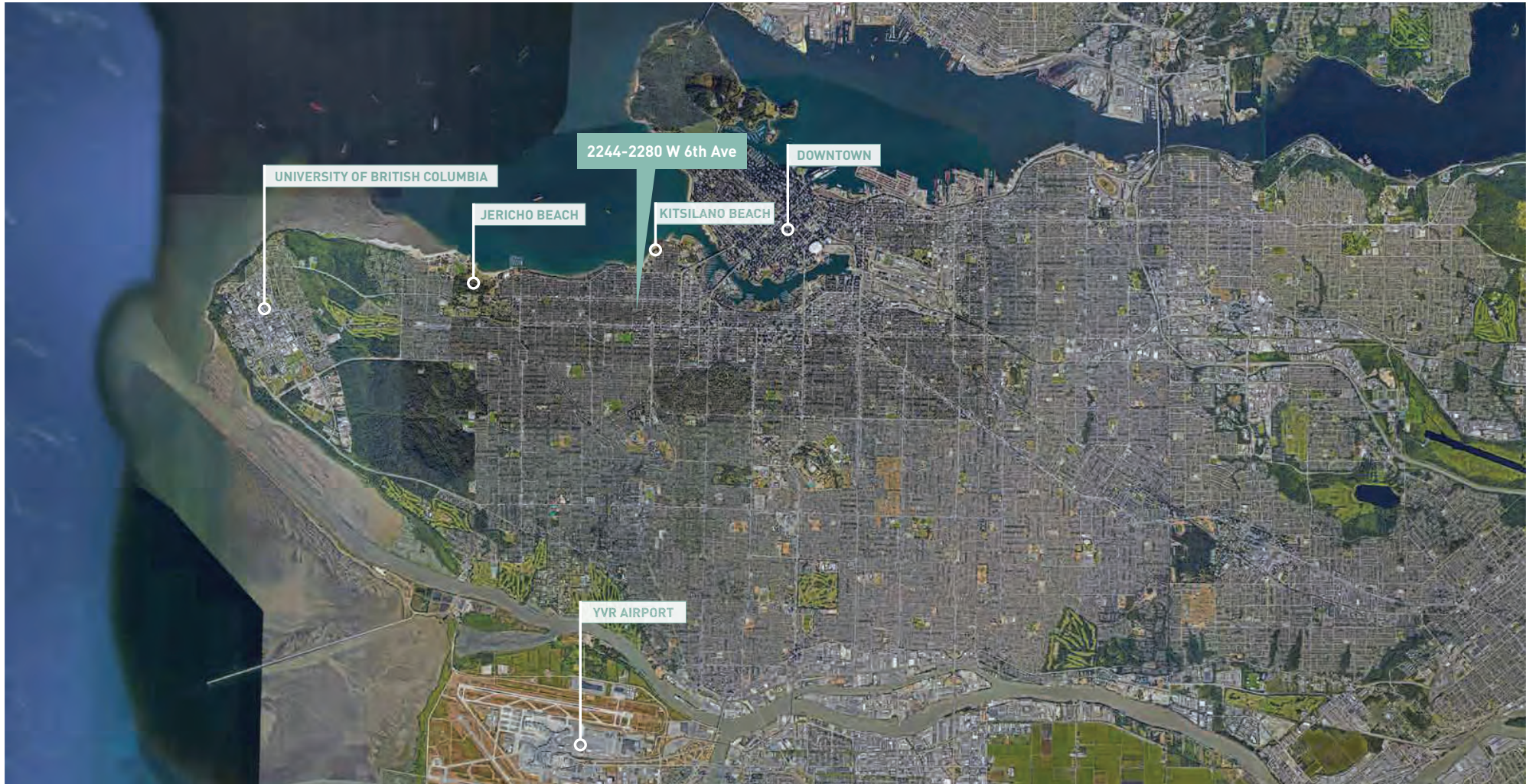
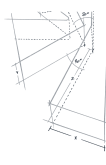

CONTEXT PLAN

The Site is approximately **500m (5 minutes)** from Arbutus station.

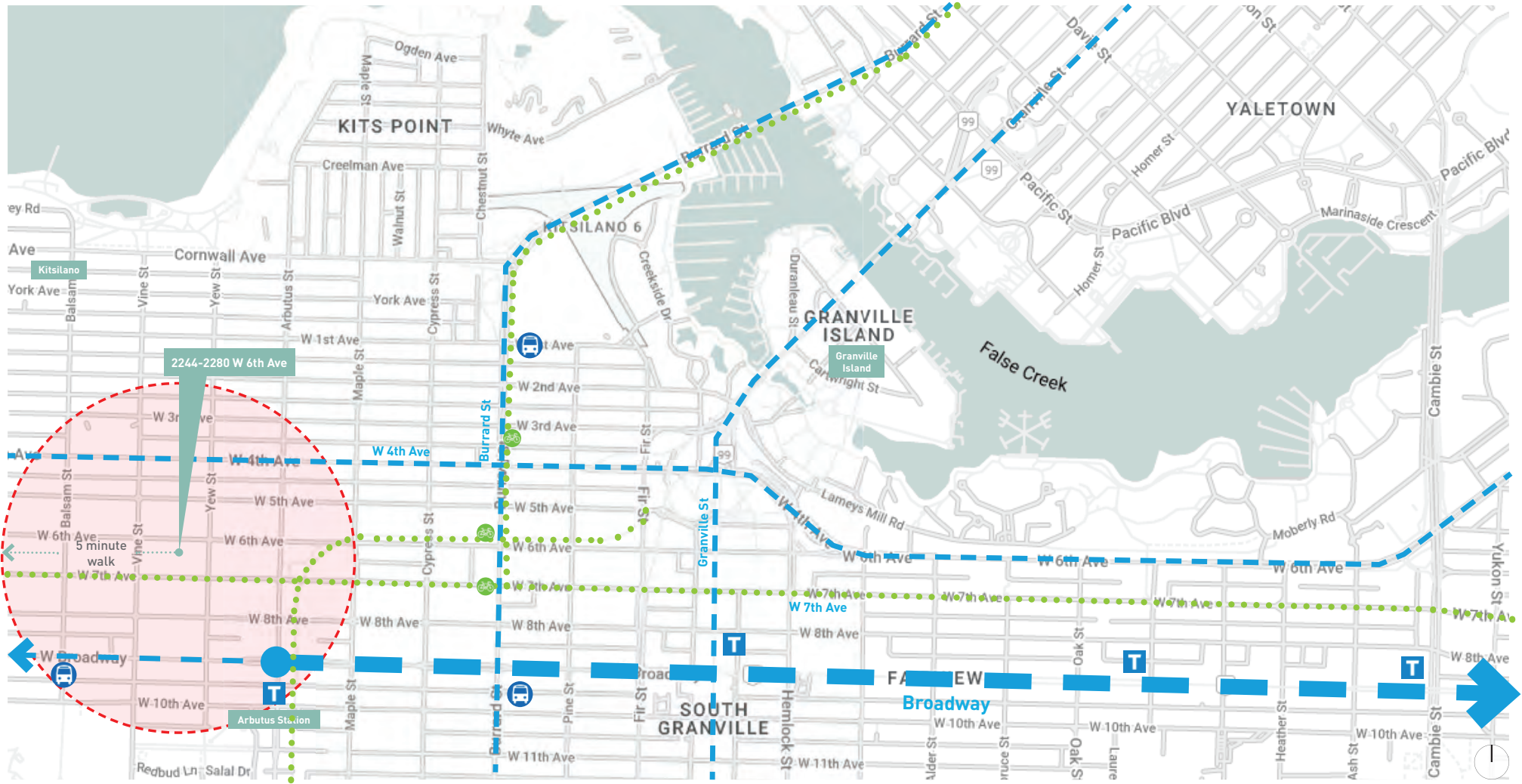

THE SITE

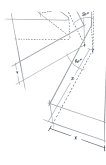

Site Description

The site is located in Kitsilano, west of Burrard Street, bordered by Yew Street and Vine Street. According to the Broadway Plan, the site is part of the KKNB (Kitsilano North - Area B) neighborhood, which primarily consists of three- and four-story multi-unit apartment buildings from the 1960s and 70s.

The site comprises two existing parcels, with a total frontage of 375 feet and a depth of 120 feet. There is no lane in this location. The existing low-rise apartment buildings contain a combined total of 89 units, with parking and services accessed via two easements directly from 6th Avenue. The gross site area is 44,992 square feet (approximately 4,180 square meters). The site is not subject to any view cone limitations or identified as a location that would create shadowing issues, as it is not in close proximity to public green space.

To the immediate east and west of the site, there are two-and-a-half-story single-family homes. To the north, there are eight city-owned boulevard trees ranging from 3 to 5 meters in height.

SITE CONTEXT

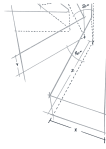

Civil Address: 2244 and 2280 W 6th Avenue

Legal Description and PID:

OT 6, BLOCK 283, PLAN VAP590, PART W1/2, DISTRICT LOT 526, NEW WESTMINSTER LAND DISTRICT 015-994-686, LOT 6, BLOCK 283, PLAN VAP590, PART E1/2, DISTRICT LOT 526, NEW WESTMINSTER LAND DISTRICT 015-994-716, LOT 7, BLOCK 283, PLAN VAP590, PART E1/2, DISTRICT LOT 526, NEW WESTMINSTER LAND DISTRICT 015-994-724, LOT 7, BLOCK 283, PLAN VAP590, PART W1/2, DISTRICT LOT 526, NEW WESTMINSTER LAND DISTRICT 015-994-741, LOT 8, BLOCK 283, PLAN VAP590, PART W1/2, DISTRICT LOT 526, NEW WESTMINSTER LAND DISTRICT 015-994-759, LOT 8, BLOCK 283, PLAN VAP590, PART E1/2, DISTRICT LOT 526, NEW WESTMINSTER LAND DISTRICT 015-994-767, LOT 9, BLOCK 283, PLAN VAP590, DISTRICT LOT 526, NEW WESTMINSTER LAND DISTRICT 015-994-775, LOT 2, BLOCK 283, PLAN VAP590, PART E1/2, DISTRICT LOT 526, NEW WESTMINSTER LAND DISTRICT 015-224-554, LOT 3, BLOCK 283, PLAN VAP590, DISTRICT LOT 526, NEW WESTMINSTER LAND DISTRICT 015-224-562, LOT 4, BLOCK 283, PLAN VAP590, DISTRICT LOT 526, NEW WESTMINSTER LAND DISTRICT 015-224-571, LOT 5, BLOCK 283, PLAN VAP590, DISTRICT LOT 526, NEW WESTMINSTER LAND DISTRICT 015-224-589

Site Statistics

2244 West 6th Avenue
 Site Width (frontage) 200'
 Site Depth 120'
 Site Area 23,999sf

2280 West 6th Avenue
 Site Width (frontage) 75'
 Site Depth 120'
 Site Area 20,993sf

Combined Areas

Site Width (frontage) 375'
 Site Depth 120'
 Site Area 44,992sf

Maximum Permitted FSR (per KNNB policy) 6.5

Maximum Buildable Area
 292,448sf



02 PROJECT CONTEXT

02.2 Photos of Site and Existing Streetscape

EXISTING STREETScape

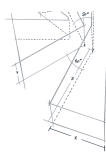

Sabanna Terrace
 2244 West 6th Avenue | Vancouver, BC
Height 3 storeys | **Built** 1969 | **Units** 46
Site Area 24,000 sf (2,230.5 sqm)
Frontage 200'
Zoning RM-4

Aquarius Apartments
 2280 West 6th Avenue | Vancouver, BC
Height 3 storeys | **Built** 1970 | **Units** 43
Site Area 21,000 sf (1,951.7 sqm)
Frontage 175'
Zoning RM-4

2205 Yew Street

2286 West 6th Avenue

2292 West 6th Avenue



West 6th Avenue facing south



West 6th Avenue facing north

PHOTOS OF SITE



1.

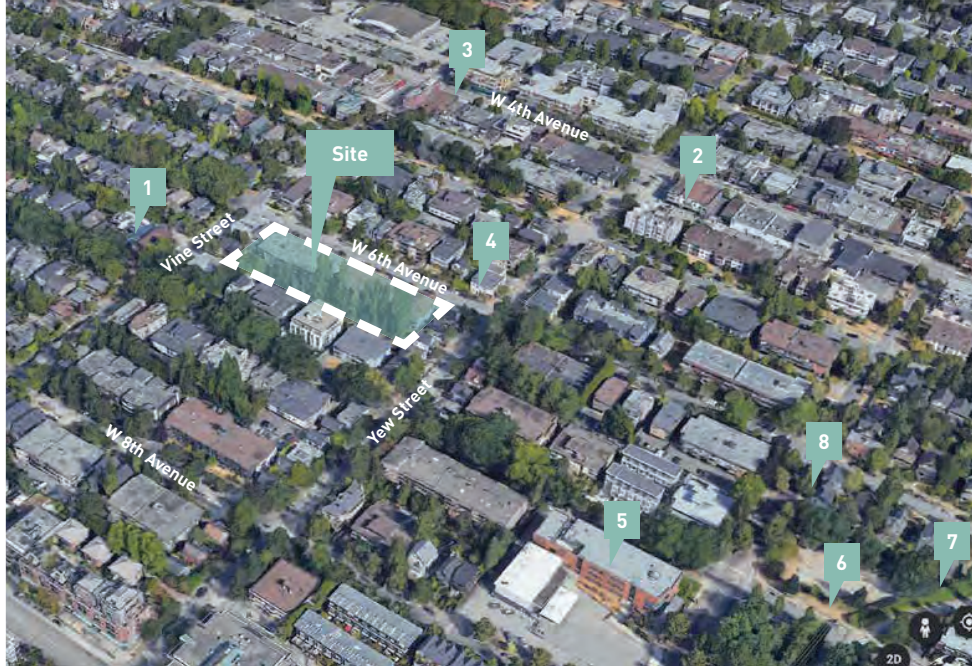

2. 49th Parallel Cafe & Lucky's Doughnuts



3. Retail / Commercial along W 4th Ave



4. Corner Store



5. St. Augustine School



8. Arbutus Coffee



7. Arbutus Greenway



6. Delamont Park



02 PROJECT CONTEXT









02.3 Zoning Context: Analysis of existing zoning in surrounding area

ZONING CONTEXT

The Current zoning is RM-4.

The surrounding sites are predominately RM-4 which is a mix of single and multi family residential building four storeys or less. The one exception is Kitsilano neighbourhood house southwest of the site which is a Comprehensive Development zoned site and provides a range of neighbourhood services.

ZONING DISTRICT

-  Site
-  Comprehensive Development
-  Commercial
-  Residential - Multiple Dwelling
-  Residential Inclusive
-  Industrial
-  Property Parcels
-  Property Parcels Lines

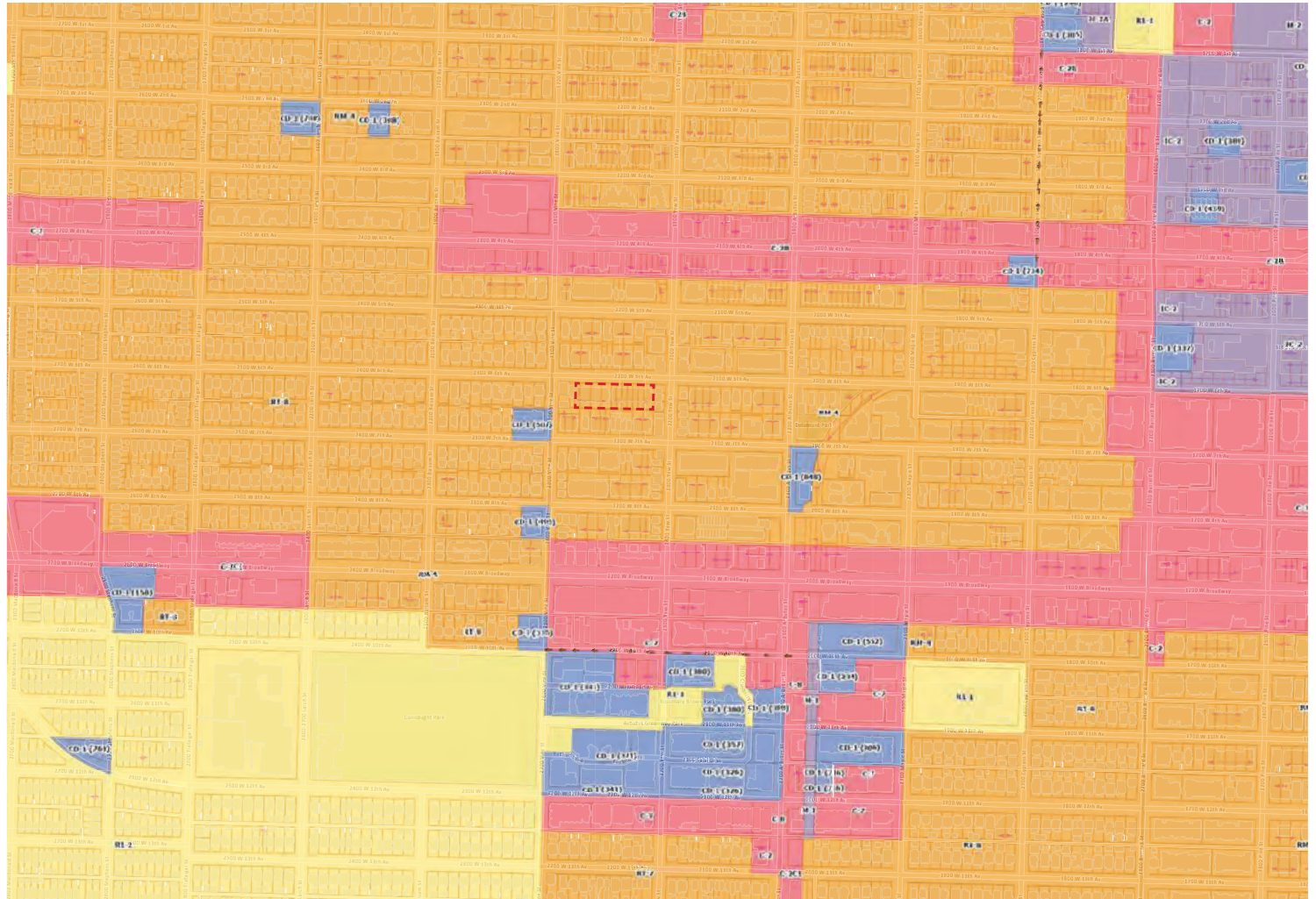

FUTURE DEVELOPMENT

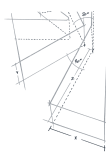

2244 - 2280 W 6th Ave



1 2267 - 2275 W 7th Ave



2 2175 W 7th Ave



3 2180 W 6th Ave



4 2225 W 8th Ave



LEGEND

- Site
-





02 PROJECT CONTEXT

02.4 Policy Context: Analysis of zoning-enabling policy, guidelines, and bulletins

POLICY CONTEXT

The design of the proposed development is informed by a robust policy analysis that includes assessment and incorporation of numerous city policies, including the following:

Community Plan Policy

- Broadway Plan
- Broadway Public Realm Plan

Housing Policies

- Vancouver Housing and Homelessness Strategy
- Housing Vancouver Strategy
- High-Density Housing for Families with Children
- Urban Agriculture Guidelines
- Family Room: Housing Mix Policy for Rezoning Projects

Sustainability and Rezoning Specific Policies

- Greenest City Action Plan
- Green Building Policy for Rezoning
- Green Buildings Policies
- Climate Emergency Action Plan
- Rain City Strategy

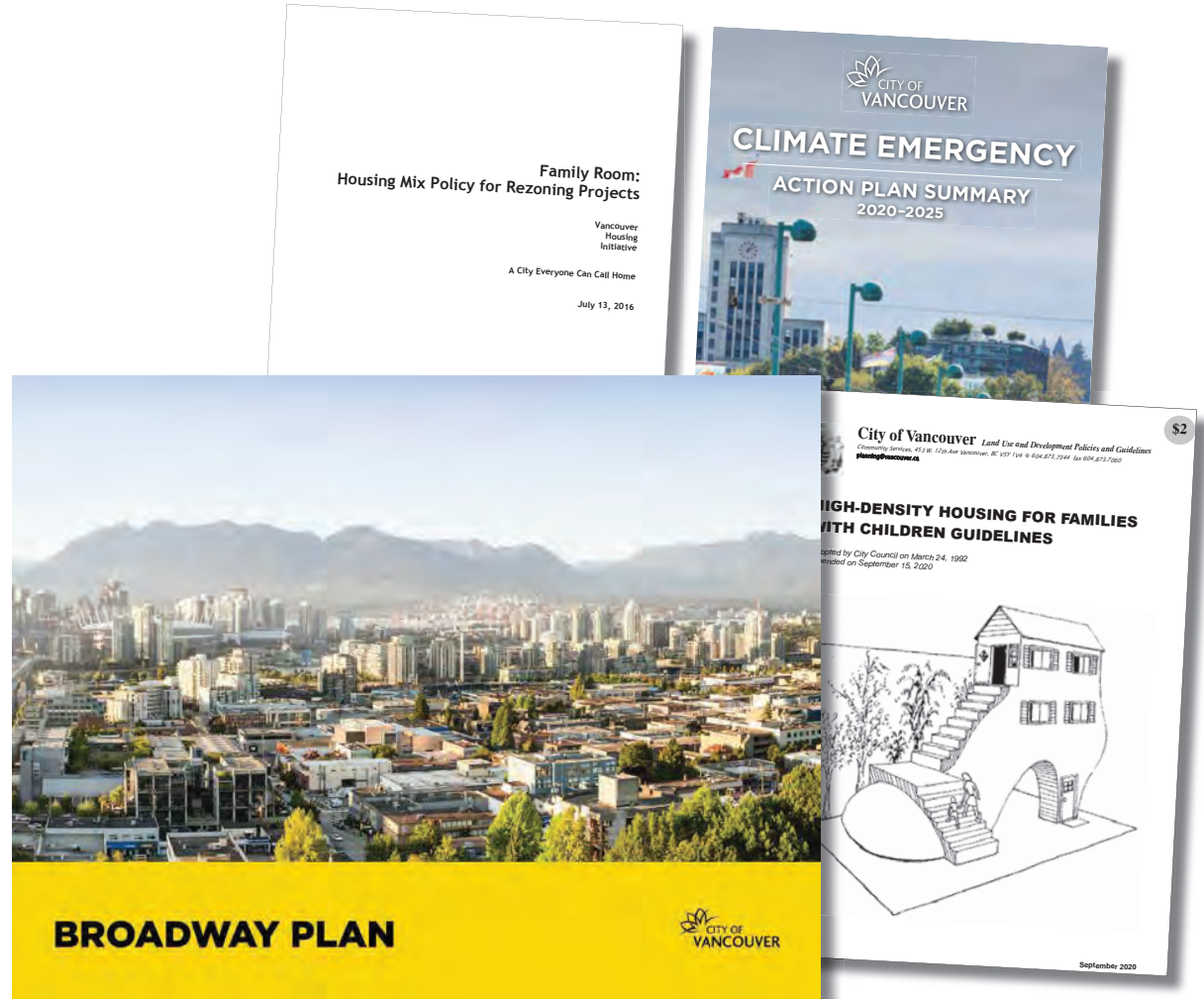

POLICY CONTEXT

Broadway Plan

The Broadway Plan was adopted in June 2022, and took effect as of September 1st 2022. The plan represents the culmination of a comprehensive planning and engagement process, centred on the Broadway corridor, extending from Clark Drive in the east to Vine Street in the west, encompassing 860 hectares (2,125 acres) of land with 485 city blocks. As highlighted in the plan document, this significant area of land is within the unceded territories of Musqueam, Squamish and Tsleil-Waututh Nations.

The plan represents a 30-year comprehensive approach to the Broadway corridor, including opportunities to address the urgency of the housing shortage crisis, provide new jobs, and provide new opportunities for amenities throughout the area. It is largely structured around the core Guiding Principles, Vision, and Intent.

The specific aspects of the Broadway Plan policy for consideration are described in the following pages of this report.

The Broadway Plan provides a clear and flexible policy framework to guide growth, positive change, and the delivery of public benefits in the Broadway neighbourhoods over 30 years, considering both long-range and shorter-term goals.

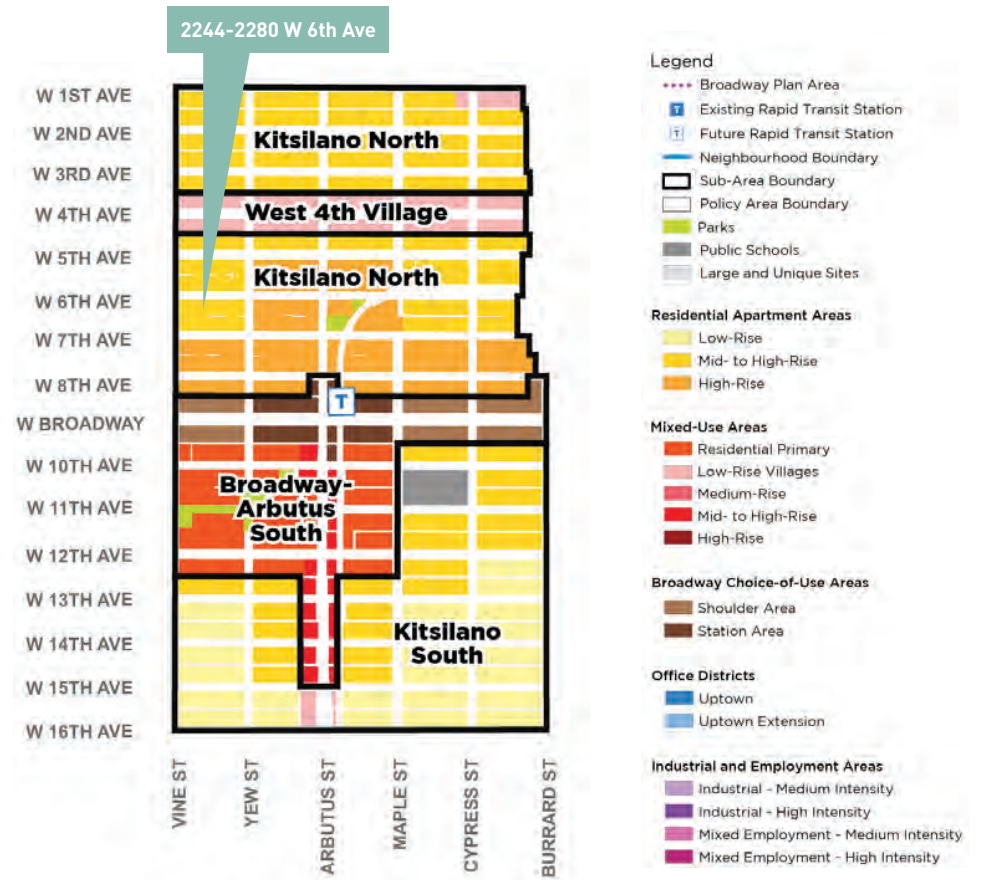

Kitsilano Neighbourhood Land Use

POLICY CONTEXT

Broadway Plan - Kitsilano North (DDNB)

Kitsilano North - Area B (KKNB)

Kitsilano North is a primarily residential apartment area with a significant stock of older rental housing. It has a variety of building types and styles that contribute to architectural diversity. Residential streets have landscaped setbacks and gardens, and large mature street trees.

Housing in the area includes a mix of character and heritage houses, many older 3-4 storey rental apartments, social housing, and strata ownership townhouses and apartments. There are a handful of small-scale cafés and grocers sprinkled throughout the residential areas, and a mixed-use retail/service node on West 1st Avenue near Burrard Street. The Arbutus Greenway passes through the area, curving from a north-south alignment to east-west at Delamont Park.

Overall Intent

Strengthen Kitsilano North as a walkable, primarily residential area with a diversity of housing options by providing strategic opportunities for new housing, encouraging the retention and renewal of the existing older rental housing, and introducing new small scale retail/service uses.

The Big Moves

- Walkable, primarily residential apartment area with diverse housing options.
- Support the long-term renewal of the older rental housing while preserving existing affordability by limiting additional density to below-market and market rental uses with enhanced tenant protection requirements for existing rental buildings.
- Encourage additional local-serving shops and services to be integrated with new apartment buildings throughout the area.

Project Approach

8.2.1 KKNB Policy Summary Table

Policy Area	Kitsilano North - Area B		KKNB	
Uses	Residential, retail/service			
Option/Tenure	Secured market rental housing or social housing		Strata ownership housing, limited to sites without existing purpose-built rental or social housing	
	Tower form	Non-tower form	Tower form	Non-tower form
Max Height	20 storeys	3-6 storeys	12 storeys	3-6 storeys
Max Density	6.5 FSR	1.0-2.7 FSR	4.0 FSR	1.0-2.7 FSR
Min Frontage	45.7 m (150 ft.)	Variable - refer to Built Form and Site Design (Chapter 11)	45.7 m (150 ft.)	Variable - refer to Built Form and Site Design (Chapter 11)
Notes	<ul style="list-style-type: none"> • A minimum of 20% of the residential floor area is required to be secured at below-market rents (see Housing (Chapter 12) for details). • For existing social housing sites, 100% of the residential floor area must be social housing. • Applies where a tower cannot be achieved due to lot conditions or policy 8.2.2. • Height and density allowances to vary based on lot conditions (see Built Form and Site Design (Chapter 11) and sections 11.2 and 11.3 for details). • See Land Use (Chapter 7) for cases where lesser site frontage may be considered at the discretion of the Director of Planning. • "Existing purpose-built rental or social housing" refers to sites where rental housing replacement requirements apply per the Rental Housing Stock Official Development Plan. 			

Additional Policies

8.2.2 For limits on the number of towers permitted on a block or block face, refer to 7.5 Tower Limit Policies.

8.2.3 Minor increases in height and density will be considered for delivery of ground-level local-serving retail/service uses or childcare. In tower forms, additional density should be limited to approximately 0.3 FSR. The combined floor area for retail/service uses should be a minimum of 139 m² (1,500 ft.²), or for childcare a minimum of 186 m² (2,000 ft.²).

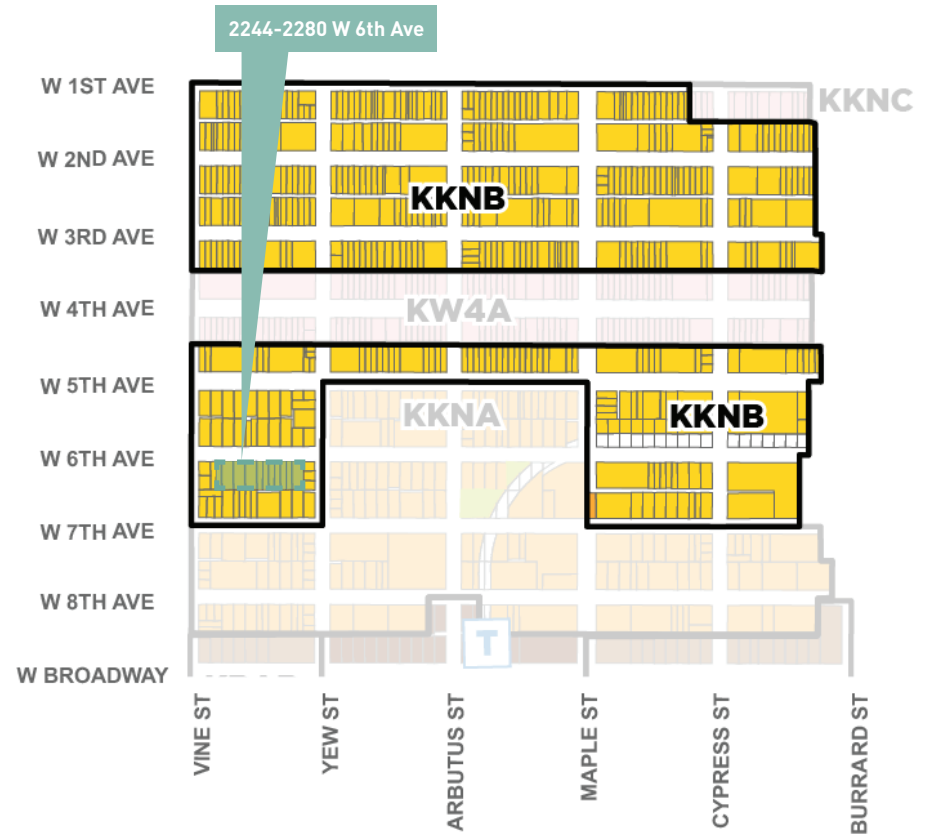

Key Takeaway: Support the long-term replacement of the older residential buildings, while preserving existing rental housing affordability levels and providing strengthened tenant protections.

POLICY CONTEXT

Broadway Plan - Residential Area Design Guidance

Residential Areas

The residential areas have a mix of housing types, with a green and leafy character and quiet, walkable streets. With a variety of buildings from different eras, these places will retain existing affordability and provide new affordable housing opportunities for a diversity of household types and incomes as well as provide local-serving shops and services to support complete neighbourhoods.

Plan Directions – Residential Areas

- Provide new affordable housing opportunities, particularly secured rental and social housing, including in off-arterial locations.
- Maintain the green and leafy character by ensuring landscaped building setbacks and opportunities for large street trees.
- In the existing apartment areas (RM/FM zones), create options for careful renewal and expansion of the existing older rental housing with a focus on maintaining affordability and supporting existing renters to stay in their neighbourhoods.
- In the existing low-density areas (RS/RT zones), diversify the housing choice with new rental apartment options while fostering a mix of building types from different periods.
- Create new options for housing ownership, which in strategic locations will also provide new social housing units as part of redevelopment.
- Enable new local-serving shops and services (e.g. small grocer, café).

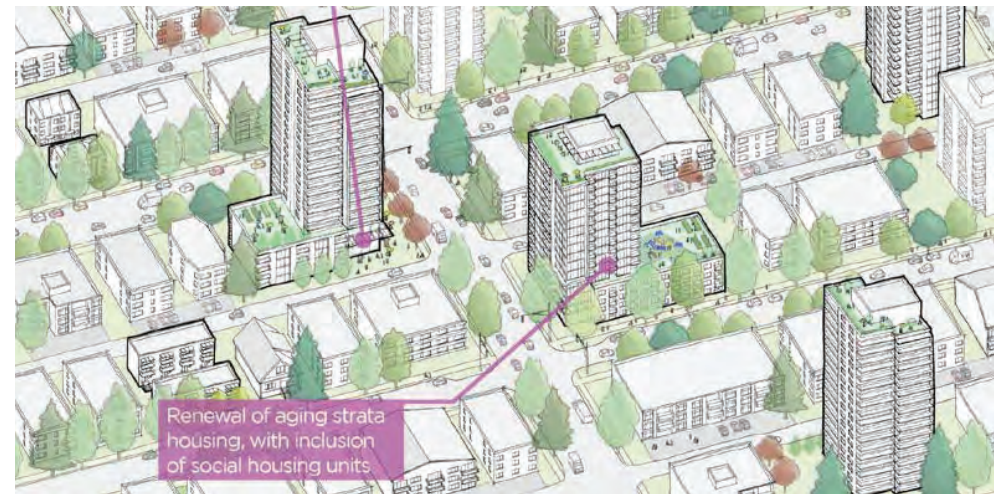
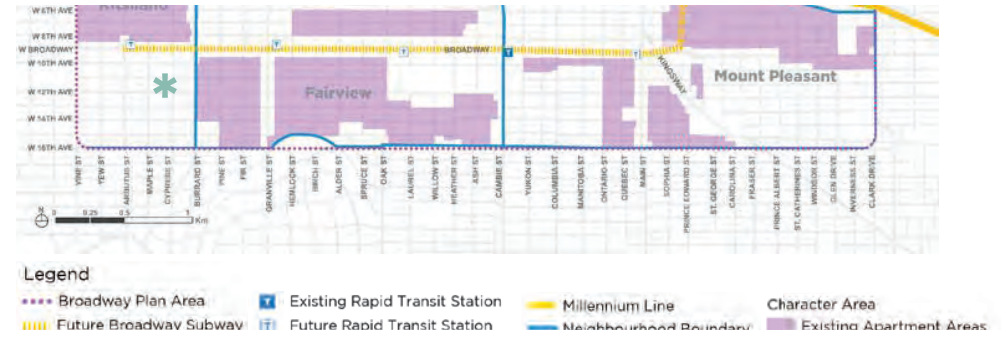

Key Takeaway: Provide new affordable housing opportunities, particularly secured rental and social housing, including in off-arterial locations.

POLICY CONTEXT

Broadway Plan: Built Form and Design Guidance Policies

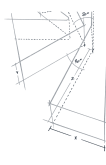

Liveable Neighbourhoods

Ensure neighbourhoods in the Broadway Plan area continue to be enjoyable, healthy, and liveable places for people of all stages of life to thrive, even as they undergo growth and change. This means:

- » Limiting the number of towers per block in residential neighbourhoods to allow adequate sunlight to adjacent homes, gardens and outdoor spaces.
- » Tower separation requirements that ensure liveability of units and access to adequate sunlight and fresh air.
- » Protecting solar access for parks, public school yards, and village high streets.
- » Building setbacks which consider angle of daylight, landscaping, and building transitions.
- » Enlivening the public realm and providing opportunities for social connection with human-scaled design that activates the public realm and creates interest.
- » Ensuring safe and comfortable street spaces for walking, rolling, cycling, and gathering.

Figure 11.1 – Generous liveable balconies



Green and Resilient Building Design

Ensure innovative green and resilient building design is embedded in the design process. This means:

- » Accommodating efficient building envelope designs and solar shading to reduce energy use and overheating.
- » Encouraging sustainable building construction including mass timber and zero emission building standards.
- » Fostering sustainable site design including significant trees and utilization of green infrastructure strategies.

Figure 11.4 - Green building and site design. Photo credit: Connect Landscape Architecture



Site Frontage and Towers

Site frontage and tower objectives are included to mitigate the impact of taller forms and ensure liveability of new units.

- 11.1.5 The minimum frontage for a site with a tower is generally 45.7 m (150 ft.) unless specifically identified in Chapters 8-10. (See Chapter 7 for cases where lesser site frontage may be considered at the discretion of the Director of Planning.)
- 11.1.6 Generally, a maximum of two towers per block will be considered in residential character areas. Refer to Chapters 8-10 for specific policies.
- 11.1.7 Tower placement should demonstrate a minimum separation between existing towers and potential future towers within the block and adjacent blocks as follows:
 - a) Residential-residential: 24.4 m (80 ft.).
 - b) Residential-hotel: 24.4 m (80 ft.).
 - c) Residential-commercial (except hotel): 18.3 m (60 ft.).
 - d) Commercial-commercial: 15.2 m (50 ft.).
- 11.1.8 Tower units should be designed so as to minimize direct line of sight between adjacent uses where possible.

Building Height

Building height varies across the Broadway Plan area. Specific building heights by policy area can be found in Chapters 8-10. Building height will also be subject to policies for building form described below.

- 11.1.14 Generally, residential floor-to-floor heights of 3.0 m (10 ft.) are supported, office floor-to-floor heights of 3.65 m (12 ft.) are supported, and industrial floor-to-floor heights of 6.1 m (20 ft.) are supported.
- 11.1.15 A partial storey for common rooftop amenity spaces is encouraged to support common outdoor amenity space. Additional height should be stepped back from building edges to minimize shadow impacts and the appearance from ground level.
- 11.1.16 Specific guidance on podium heights and street wall lengths vary by building typology and can be found in sections 11.2 - 11.9.

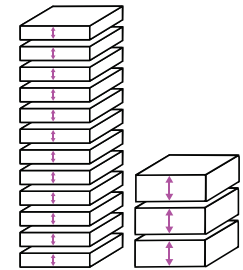

Illustrative example of floor-to-floor heights

POLICY CONTEXT

Broadway Plan: Built Form and Design Guidance Policies

Building Width and Depth

Building width and depth should consider the experience of the public realm and liveability of units.

- 11.1.17 Long facades should incorporate significant articulation and recessed setbacks to break up expanses of wall planes.
- 11.1.18 For residential units with a single exterior façade, overall unit depth should generally be limited to 10.6 m (35 ft.). Unit depths greater than 12.2 m (40 ft.), without a second solar and ventilation access (e.g. courtyard scheme) should be avoided.

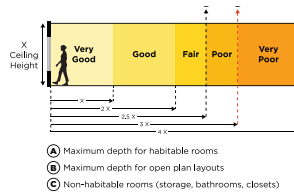

Figure 11.9 Light penetration.
(Adapted from Perkins+Will)

Outdoor Space

Outdoor space should offer people quick and direct access to the fresh air and nature and provide important opportunities for social connection. Outdoor spaces should be designed for functionality as a private/semi-private spaces.

- 11.1.22 All residential units should have access to private outdoor space, i.e. patio and/or balconies.
- 11.1.23 If site conditions prevent all residential units from having private outdoor space, alternatives that demonstrate exemplary and commensurate common outdoor amenities may be considered.
- 11.1.24 For outdoor amenity spaces and facilities that support communal meals, gathering and socializing, agriculture planters should be provided.
- 11.1.25 Consider locating outdoor amenity spaces adjacent to or visible from indoor shared space for passive supervision.
- 11.1.26 Rooftop outdoor amenity spaces should be designed to include appropriate tree and planting species and provide protection from the wind, sun and rain.
- 11.1.27 The Childcare Design Guidelines should be referred to for any site identified for the delivery of childcare.
- 11.1.28 Buildings should be designed to maximize sunlight on outdoor play spaces.
- 11.1.29 Privately Owned Public Spaces (POPS) are encouraged, particularly at large and unique sites, along Broadway and commercial streets. See Public Realm Framework Chapter 15 and Land Use Chapters 8-10 for more information on POPS.



Figure 11.10 Usable outdoor space including privacy screening



Figure 11.11 Shared rooftop amenity space

Architecture

Architectural components should recognize the importance of Central Broadway as Vancouver's "second downtown" and contribute to the human experience and liveability of the Plan areas highly urban neighbourhoods.

- 11.1.30 Express a finer grain urban fabric by articulating smaller increments and modules, particularly at ground level.
- 11.1.31 Acknowledge the liveability of adjacent residential units by avoiding primarily aesthetic architectural or lighting designs that create light pollution or otherwise impact the health and well-being of residents.
- 11.1.32 Building architecture should be of its time while considering the architectural history of the neighbourhood, the surrounding neighbourhood context, and the emerging character of the neighbourhood.
- 11.1.33 New developments adjacent to buildings on the Vancouver Heritage Register should respect their scale, façade proportions, and design.
- 11.1.34 Existing site or building elements that contribute to the identity of the neighbourhood should be considered for integration into new developments where feasible.
- 11.1.35 Within a single, strong architectural concept, variety is encouraged between buildings to avoid repetition and to create an interesting streetscape environment.
- 11.1.36 Typically, residential buildings will have a secondary expression at the higher level with a clear expression of the base and entry.
- 11.1.37 Building entrances should be clearly recognizable and appropriately scaled to the street and the neighbourhood context. They should be clearly expressed with distinct signage, canopies, landscaping elements, and/or other architectural features.
- 11.1.38 Where located near or adjacent to rapid transit stations, development must address specific architectural and urban design considerations to meet station overbuild and integration objectives. See Section 11.10 Transit Integration and Urban Interface.

POLICY CONTEXT

Broadway Plan: Built Form and Design Guidance Policies

Interface with the Public Realm/Residential Street

The role of front and back yard spaces evolves as neighbourhoods change. These outdoor spaces need to meet both the privacy and socialization needs of residents while maintaining a welcoming and attractive urban environment.

- 11.1.51 Front building facades should be animated with entrances, windows, balconies and/or patio spaces, creating active and engaging edges that promote social interaction and the use and enjoyment of outdoor space.
- 11.1.52 Weather protection should be provided for common entrances, and for exterior residential entrances.
- 11.1.53 Building and landscape design should create clearly delineated transitions from the public realm to the private. At each transition, consider how layers of planting and/or grade change can be utilized to provide the appropriate balance of privacy and sociability.
- 11.1.54 The use of hedges and planted barriers or screens are encouraged, however, full height, solid fencing and other continuous visual barriers should be minimized allowing filtered views between spaces.
- 11.1.55 To enhance seating predictability for accessibility, consider providing an on-site bench or small seating area accessible from the sidewalk on corner sites on residential local streets. Design and position seating thoughtfully to avoid conflicts with private or shared open spaces and to maintain the privacy of ground-floor units.
- 11.1.56 Lane buildings should activate and animate the lane with entrances and windows that directly face the lane. Blank or opaque facades should be avoided.



Figure 11.15 Clearly delineated transitions from public to private

Figure 11.17 Typical Residential Street Frontage with Boulevard (for illustrative purposes only)

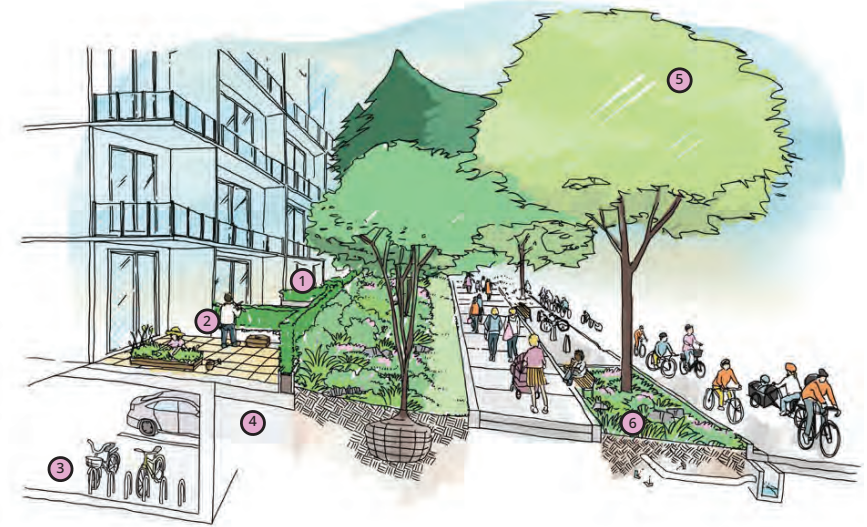

- 1 Planting provides a buffer between private patios and public streetscape
- 2 Private Patio
- 3 Parking access off the lane, to reduce driveways on local streets
- 4 Parkade slab set-back to provide adequate space and soil volume for planting
- 5 Streetscape elements in boulevard (seating lighting, public art, public bike share)
- 6 Rain garden and tree planting within expanded boulevard

POLICY CONTEXT

Broadway Plan: Built Form and Design Guidance Policies

Sustainability

New developments should incorporate green building and site design principles that reduce carbon pollution and support a healthy environment.

- 11.1.57 New construction should explore innovative low carbon building technologies, such as mass timber construction, and the form of development should permit energy efficient design and the use of standardized modules.
- 11.1.58 Maximize tree retention, new trees and large specimen replacement trees to support a healthy urban forest canopy and reduce urban heat island effects.
- 11.1.59 Below grade parkades should be set back from the front property line to provide adequate space and soil volume for trees and green rainwater infrastructure. Parkades should be notched at the site perimeter to support tree retention and growth. Where tree planting on slab, soil depths should meet the Canadian Society of Landscape Architects (CSLA) Canadian Landscape Standard.
- 11.1.60 Landscaping should be integrated along rear lanes where possible.
- 11.1.61 Enhance habitat for birds, pollinators, and other flora and fauna where possible.
- 11.1.62 Incorporate strategies for integrated rainwater management in frontage improvements, landscaped areas, public plazas and outdoor amenity spaces.
- 11.1.63 Green roof technologies should be considered to enhance open space, reduce stormwater volume, and mitigate heat island effect.
- 11.1.64 Solar shading devices integrated into the overall building expression should be incorporated where appropriate.



Figure 11.19 Ecological landscaping



Figure 11.20 Simple, energy efficient building forms: Shift by the Office of McFarlane Biggar Architects + Designers Inc

Parking and Loading

The location and design of parking and loading components should limit negative impacts on the public realm and balance the functionality of these spaces with a high quality urban experience.

- 11.1.65 Parking entries, loading and service facilities should be located at the lane. Where lane access is not available, these elements should be located to minimize impact on key pedestrian and cycling connections and frontages.
- 11.1.66 Screening in the form of feature landscaping or architectural treatment should be provided where required to visually divide service areas from the public realm.
- 11.1.67 Loading spaces may be located at grade open to the lane, but should be solidly roofed to avoid noise and visual impacts. Negative impacts are to be avoided through appropriate height, lighting, painting, and screening (including doors).
- 11.1.68 Loading spaces should be securable at night for safety reasons.
- 11.1.69 Building entrances and layouts should be designed to facilitate easy access to secured bike parking and storage.
- 11.1.70 Where lane access is not available, land dedications may be required for provision of a future lane.
- 11.1.71 Given the variety of industrial and employment uses allowed in the Mount Pleasant Industrial Area, the Director of Planning may consider relaxations to loading requirements under the Parking By-law depending on the anticipated and demonstrated loading needs of the building based on its uses as well as site constraints such as heritage retention and conservation or the provision of privately-owned public spaces (POPS).

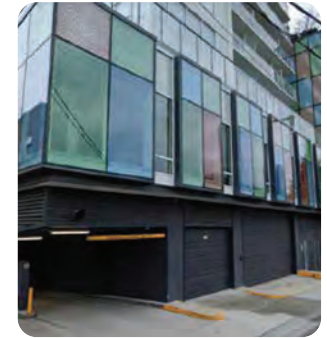

Figure 11.21 Underground parkade entrance integrated into building architecture

Solar Access

Applicability

Solar access requirements in the Broadway Plan area apply to parks, public school yards, and village shopping streets/plazas existing or in development at the time of adoption of the Broadway Plan.

Shadow limits

Proposed new development should not create new shadow impact on parks and public school yards from the spring to fall equinoxes between 10AM and 4PM.

Proposed new development should avoid creating new shadow impacts on the opposite sidewalk in village high streets (see Character Areas Chapter 6 for locations of villages) from the spring to fall equinoxes between 10AM and 4PM.

- For new buildings east of a village high street, protections apply to the western sidewalk.
- For new buildings west of a village high street, protections apply to the eastern sidewalk.
- For new buildings south of a village high street, protections apply to the northern sidewalk.

Key Takeaway: Goals to increase housing will result in greater densities and building heights. Built form and site design principles should be carefully considered to ensure desired urban design performance.

Key Takeaway: Ensure neighbourhoods in the Broadway Plan continue to be enjoyable, healthy, and liveable places for people of all stages of life to thrive

POLICY CONTEXT

Broadway Plan: Mid to High-Rise Apartment Design Guidance

Tower Floor Plates

- 11.4.12 For lot depths of 36.6 m (120 ft.) or greater, maximum tower floor plates of 604 m² (6,500 ft.²) are recommended.
- 11.4.13 For lot depths less than 36.6 m (120 ft.), tower floor plates less than 604 m² (6,500 ft.²) will be recommended to ensure adequate setbacks and solar access.

Tower Separation

- 11.4.14 A residential tower will be considered as any part of a building higher than 4 storeys with the exception of developments where a 6 storey podium is permitted as per policy 11.4.3.
- 11.4.15 Ensure tower setbacks provide half of the required tower separation for each site, typically as follows:
 - a) 12.2 m (40 ft.) from the side interior property line.
 - b) 9.1 m (30 ft.) from the rear property line, after accounting for lane dedication, if necessary.

Side yard tower setbacks may be reduced to 6.1 m (20 ft.) if the required tower separation is maintained and the development potential of adjacent sites is not compromised. Generally, interior side yard tower setbacks should be at least 6.1 m (20 ft.).

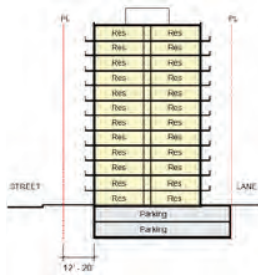

Figure 11.39 Typical 12 storey apartment (section)

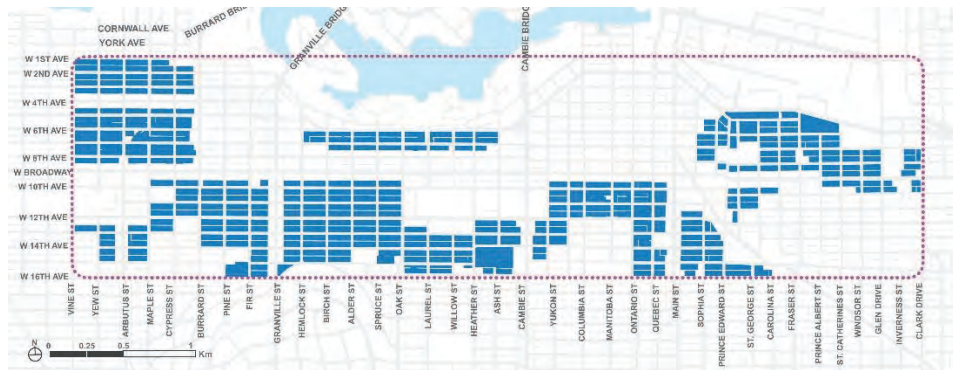

Figure 11.33 - Key map identifying areas where this typology is enabled

Building Height

- 11.4.1 Building heights vary. Refer to the applicable policy area in Chapters 8-10 and the applicable R4 or R5 District Schedules for details.
- 11.4.2 A consistent 4-storey podium should be provided in residential areas to create a consistent street wall that is compatible with existing neighbourhood character and *preserves* solar access across the street.
- 11.4.3 Additional height will be considered for floor-to-floor height increase with ground level commercial uses.

Site Requirements

- 11.4.5 Minimum frontage: 45.7 m (150 ft.). (See Chapter 7 for cases where lesser site frontage may be considered at the discretion of the Director of Planning.)
- 11.4.6 Minimum lot depth: 33.5 m (110 ft.); rear laneway required.

Setbacks

Setbacks for mid- to high-rise residential buildings should balance the liveability of new homes (usable outdoor space, daylight and ventilation) with those of the broader community (minimizing overlook and shadowing). See the applicable R4 or R5 District Schedule and associated design guidelines for details.

Podium

- 11.4.7 Front yard setbacks should be a minimum of 3.7 m (12 ft.). Where possible, larger front yard setbacks that better align with adjacent buildings and provide more usable outdoor space for ground floor units are desirable.
- 11.4.8 Underground parking structures should be set back from the front property line and exterior side yard (where applicable) by 3.7 m (12 ft.) to ensure adequate soil depth for healthy trees are desired. Where roughly equivalent site area is provided, alternative alignments for underground setbacks may be considered to better accommodate high-value tree retention, onsite tree planting (e.g. within an enhanced open space setback), or to support green rainwater infrastructure associated with blue green systems.
- 11.4.9 Side yard setbacks for the podium should be a minimum of 3.7 m (12 ft.).
- 11.4.10 Rear yard setbacks should allow for usable ground floor outdoor space, support the liveability of residential units, and consider solar access and overlook for adjacent properties.
- 11.4.11 Development on larger sites with a frontage of 60.7 m (199 ft.) or greater should provide an at-grade Enhanced Open Space Setback (EOSS), utilizing additional building height (per 11.4.4) to reallocate density. The EOSS should comprise approximately 20% of the frontage length that extends the full depth of the site. This space is intended primarily for publicly accessible greenspace and park-like space. Other uses may be considered on a case-by-case basis (e.g. outdoor child day care spaces). See the Broadway Public Realm Plan for further design guidelines for EOSS.



Figure 11.38 Outdoor amenity space

POLICY CONTEXT

Broadway Plan: Mid to High-Rise Apartment Design Guidance

Outdoor Space

To enhance the liveability of mid- and high-rise apartment buildings, outdoor space should be prioritized and allow for a range of activities for all ages including eating, socializing, outdoor play, gardening, and enjoyment of nature. Providing housing for families in mid- to high-rise buildings is enhanced by the inclusion of private outdoor space and thoughtful communal play spaces.

- 11.4.16 Where possible, ground floor units should open onto usable outdoor space.
- 11.4.17 Where ground floor units are accessed primarily from an interior corridor, outdoor spaces should be designed as 'backyards' with improved privacy screening and more generous dimensions.
- 11.4.18 Shared outdoor amenity space should be provided at the ground floor, podium and/or rooftop.
- 11.4.19 A portion of the shared outdoor amenity space should be designed to support children's play with a focus on flexible features, innovative play spaces, and exploratory structures.
- 11.4.20 "Tower-in-open space" typologies should be extensively landscaped to enhance the overall green space experience within the surrounding neighborhood.



Figure 11.40 Communal gardening space



Figure 11.41 Children's play space



Figure 11.36 - Typical 20 storey apartment (axo)

Key Takeaway: Mid to high-rise buildings will provide increased housing opportunities within quiet residential neighbourhoods. Building and site design should ensure new development is sensitive to context, responds to the pattern and character of the existing neighbourhood, and minimizes shadowing and overlook impacts on adjacent homes and open space

POLICY CONTEXT

Broadway Plan: Greenway

Figure 14.5 Priority Walking and Rolling Routes within the Broadway Plan Area

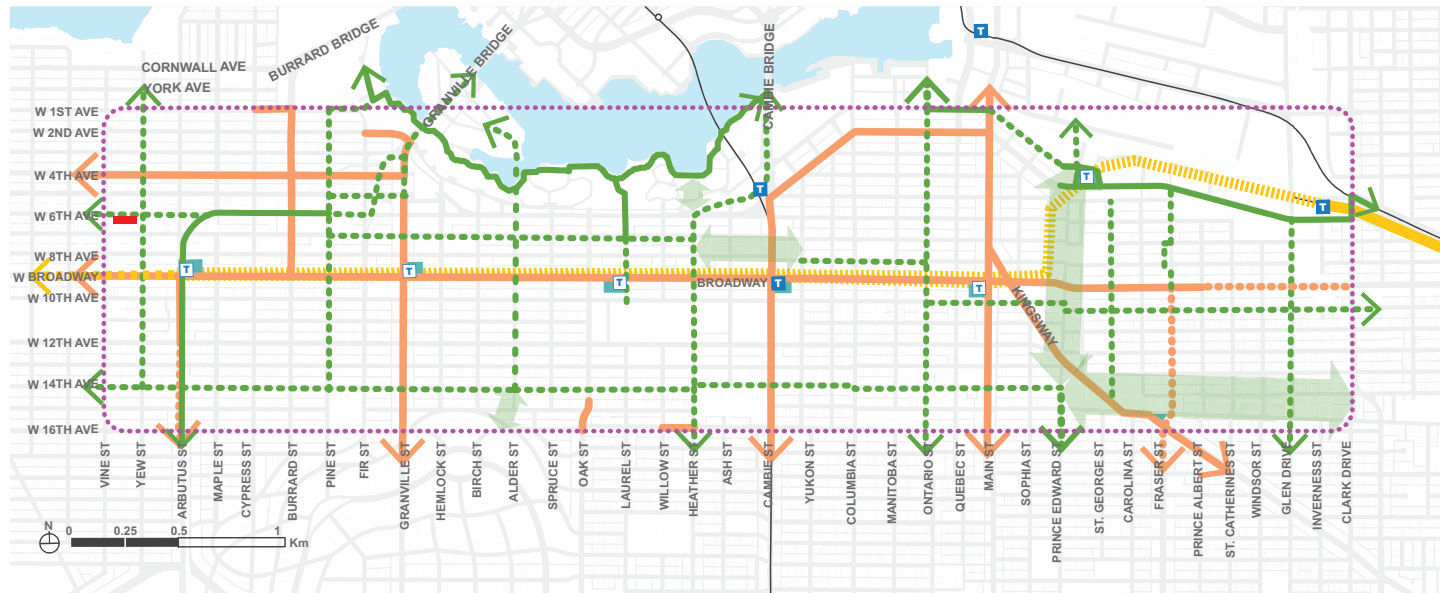

NOTE

While the map only highlights the priority pedestrian routes, the City will improve the conditions for pedestrians in the area overall.

Where a greenway connects to a park, there will be further work and consultation to determine if the greenway will go through or around the park.

Legend

- Broadway Plan Area
- ||||| Future Broadway Subway
- |||| Future Millennium Line UBC Extension
- Millennium Line
- Current SkyTrain Network
- T Existing Rapid Transit Station
- T Future Rapid Transit Station
- Site
- Existing Commercial Street
- Future Commercial Street
- Existing Greenway
- Future Greenway
- Further Work Required to Determine Greenway Alignment
- Activity Node

POLICY CONTEXT

Broadway Public Realm Plan

Enhanced Open Space Setback on Tower Sites in Residential Areas

Intent

Ensure trees, green space and park-like spaces are being delivered in areas with new residential development. This section specifically applies to tower developments in the Residential Areas with a site frontage of 60.7 m (199 ft.) or greater. See the Broadway Plan Built Form and Site Design policies for more details.

Rationale

As residential sites redevelop and intensify, there is a tendency to lose large existing trees and tree canopy. Large sites have the flexibility to create at-grade open space that smaller sites cannot. On-site space can be secured for tree planting as well as existing tree retention through the Enhanced Open Space Setback (EOSS). These Enhanced Open Space Setbacks present an opportunity to create park-like play areas and green spaces for public use as well as manage stormwater through on-site infiltration.

Guidelines

- 1.4.1. To improve predictability in seating locations for accessibility, corner sites on residential local streets should provide an on-site bench or small seating area accessible from the sidewalk.
- 1.4.2. Green space including trees should be prioritized within the EOSS. At least 50 per cent of the area should be planted area. Prioritize planting medium to large tree species in ground where the EOSS aligns with an underground setback. See Figure 70.

Figure 70. Tree and shrub planting within EOSS

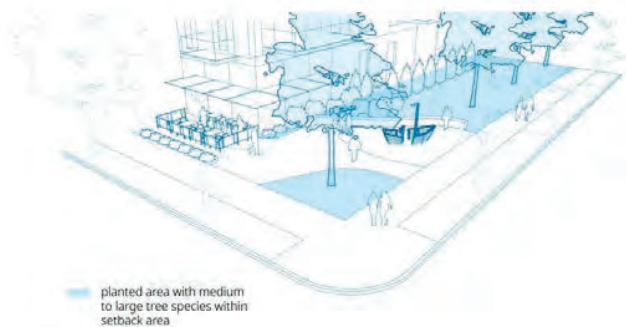

- 1.4.3. When the EOSS is located along the exterior side yard, avoid providing paths to private yards and minimize the number of building entries/exits through the EOSS so as to not fragment otherwise contiguous public space. See Figure 71.

Figure 71: Approaches to maximize contiguous open space

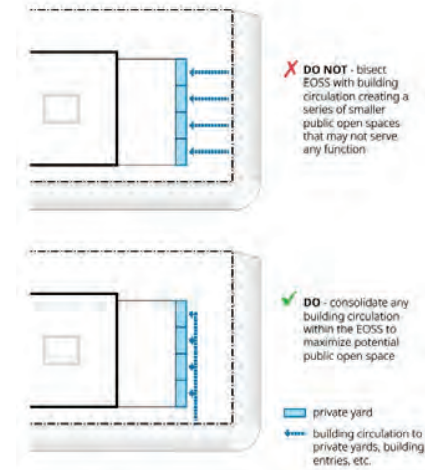

- 1.4.4. When the EOSS is located on the interior side yard or mid-site, a midblock connection may be desired, especially if it connects to a destination such as a park or public space, community centre, subway station, commercial high street or to another street.

POLICY CONTEXT

Broadway Public Realm Plan

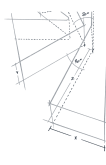

Public Spaces on Large and Unique Sites

Intent

Secure large spaces for dedicated parks and provide finer grain connections through large sites. Where dedicated parks are not feasible, park-like POPS may be considered. This section specifically applies to development on Large and Unique Sites, as identified in the Broadway Plan.

Rationale

Redevelopment on Large and Unique Sites can help deliver larger public spaces, and parks in particular, that can be programmed, serve multiple functions and have concurrent uses in ways that smaller spaces do not typically allow. This may include substantial green space, recreational uses, play areas, event spaces and urban agriculture. This approach requires intentionally consolidating on-site open space to maximize its design potential. Midblock connections should be provided to improve connectivity through the site, to the on-site open space, to existing destinations and provide relief from building massing.

Guidelines

- 1.5.1 Where possible, development on Large and Unique Sites should target a minimum of 20 per cent of total site area for public space, including midblock connections. Maximize the amount of contiguous open space that would contribute to a dedicated park or designated POPS.
- 1.5.2 Public spaces should be located where they receive the most amount of direct sunlight and sky views. Consider the use and function of the space to determine the time of day and year when sunlight is most important.
- 1.5.3 Public spaces should be sited to retain existing trees and/or to provide space in the ground (without below-grade structures) for new trees. Other suitable locations may include:
 - On the interior of a site, in a courtyard like space. This should have high visibility from the street, universal accessibility from at least one sidewalk and a publicly accessible pathway through the site to the space.
 - Along the street or at the corner for high visibility, where the grading is shallow enough to provide good accessibility, to simplify delivering park dedications or where they align with greenways, blue green systems or other car-free streets. Local streets are preferred over arterial streets.
 - Multiple locations tied together with a strong pedestrian connection may be appropriate depending on site context but should not be prioritized over a single large space.

Figure 77. Example scenarios for locating public spaces on Large and Unique Sites

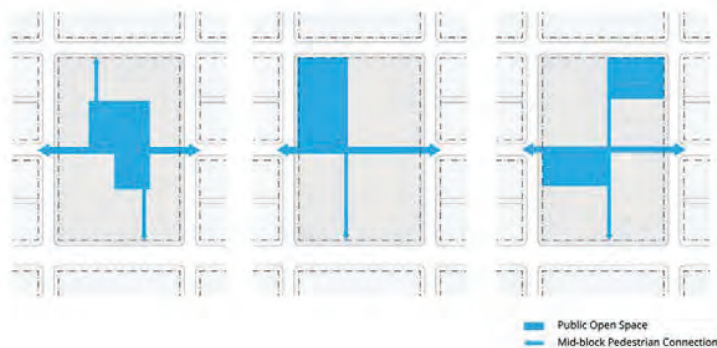

- 1.5.4 Pedestrian connections through sites should be provided to connect to existing streets, pedestrian connections and to key destinations such as parks, commercial high streets and SkyTrain station entries. Consider how these connections can improve universal accessibility.
- 1.5.5 Avoid locating pathways for building entries and circulation through the public spaces in a way that bisects or interferes with design of that space.
- 1.5.6 Avoid creating long, narrow public open spaces that cannot accommodate a wide range of uses.
- 1.5.7 Consider providing standalone weather protection, especially where a plaza is provided.
- 1.5.8 Events infrastructure (e.g. lighting, electrical receptacles, water supply, storage, etc.) may be desired on a case-by-case basis.
- 1.5.9 Design spaces for uses typically found in parks such as playgrounds, sports courts, recreational facilities, community gardens and biodiversity planting that are more difficult to provide in smaller spaces. Consider which of these uses may be most suited to the building program and what might meet the needs of the neighbourhood.

Guidelines for Dedicated Parks

- 1.5.10. Locate parks to be highly visible and, where adjacent to ground floor residential uses, bordered by public streets and/or public pathways to enhance their public use, increase accessibility and provide vehicle access for maintenance and operations. The following spaces will not be counted as park space:
 - Spaces serving primarily public transit access.
 - Spaces for rainwater capture or mobility functions without opportunities for public gathering, access to nature and/or recreation use.
 - Areas adjacent to the school facilities for exclusive daytime use of Vancouver School Board.
 - Spaces associated with residential or retail/commercial uses or that could reasonably be perceived as semi-public.
- 1.5.11. Configure parks to have regularized parcels that work with the topography and are not fragmented or organized around ground-floor uses serving primarily a private function. Where buildings are adjacent to parks, provide pathways on private property for access to ground floor residential units.
- 1.5.12. Recognize separation between parks and private residential outdoor space through changes in elevation, material changes at setbacks and rainwater features that define transitions.
- 1.5.13. Locate parks on 'terra firma' where the parcels are not encumbered by non-park related surface and underground structures (e.g. parkades, utilities) or other encumbrances such as easements and statutory rights-of-way.
- 1.5.14. Identify opportunities for a limited amount of rainwater management within park areas provided it does not impact park service levels and programming. Ensure that seasonal rainwater management areas are designed and managed to provide other park programming and purposes outside of major storm events.
- 1.5.15. Determine the final program and design of the park through a collaborative process with the City.

REZONING POLICY COMPARISON

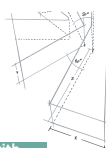

	Broadway Plan Policy Letter of Response	Proposed Development	Conforming with Broadway Plan and Municipal Responses
Uses (8.2.1)	Residential, retail/service	Residential	Yes
Tenure (8.2.1)	Secured market rental housing or social housing	Market rental housing	Yes
Max Height (8.2.1)	25 storeys	22 storeys	Yes
Max Density (8.2.1)	6.5 FSR	6.5 FSR	Yes
Min Frontage (8.2.1)	150 ft.	175 ft. for 2280 W 6th Ave., 200 ft. for 2244 W 6th Ave.	Yes
Towers per Block (8.2.2 and 7.5)	For limits on the number of towers permitted on a block or block face, refer to 7.5 Tower Limit Policies. Generally, tower limit policies do not apply for blocks in residential areas that are mostly within 400 metres of rapid transit stations, or are close to other transit, shops, services, and amenities.	Two towers provided	Yes
Tower Placement (11.1.7, 11.1.8 and 11.4.15)	Tower placement should demonstrate a minimum separation between existing towers and potential future towers within the block and adjacent blocks as follows: a) Residential-residential: 24.4 m (80 ft.). b) Residential-Hotel: 24.4 m (80 ft.) to 18.3 m (60 ft.). c) Residential-commercial (except hotel): 18.3 m (60 ft.). d) Commercial-commercial: 15.2 m (50 ft.). Tower units should be designed so as to minimize direct line of sight between adjacent uses where possible. 12.2 m (40ft.) from the side interior property line	81 ft. provided between towers. To ensure an 80-meter separation between potential towers on adjacent properties, all towers maintain a 40-foot setback from the shared internal property lines.	Yes
Residential Floor to Floor (11.1.14)	Residential floor-to-floor heights of 3.0 m (10 ft.) are supported	10 ft. floor-to-floor heights are provided in all residential floors, loft units has a 20'-0" floor-to-floor at the living and 10'-0" at the mezzanine	Yes
Building Width and Depth (11.1.17)	Long façade should incorporate significant articulation and recessed setbacks to break up expanses of wall planes.	Break down the mass by separating the building face with the recessed balconies at the corner and at the middle of the tower.	Yes
Building Width and Depth (11.1.18)	For residential units with a single exterior façade, the overall unit dept should generally be limited to 10.6 m (35 ft.).	The units that face a single exterior façade have a depth of 9.6 m (31'-6"), which is less than the maximum of 10.6 m (35ft.) requirements.	Yes

	Broadway Plan Policy Letter of Response	Proposed Development	Conforming with Broadway Plan and Municipal Responses
Livability Private Outdoor Space(11.1.22)	All residential units should have access to private outdoor space, i.e. patio and/or balconies.	Generous private patios and backyards are provided to all the ground units and units at the podium rooftop, balconies are provided to all the rest of the units. The minimum depth for the balconies is more than the minimum of 6'-0" requirements. The maximum depth varies from 8'-4" to 9'-6".	Yes
Pedestrian Realm Interface - Animated (11.1.51)	Front building facades should be animated with entrances, windows, balconies and/or patio spaces, creating active and engaging edges that promote social interaction and the use and enjoyment of outdoor space.	The building front façades are created by large full height curtainwalls, including the main entry at the center and private patios with landscape buffers.	Yes
Pedestrian Realm Interface - Weather protection (11.1.52)	Weather protection should be provided for common entrances and for exterior residential entrances.	A large canopy is provided at the main entry, combined with the screens serving as the guardrails when higher than 2', at the accessible path to the main entry. Pergola covers and wind screens are provided at the outdoor amenities such as outdoor gym, outdoor spa, and outdoor BBQ areas. All the exterior doors from the units to private outdoor spaces are covered by the balconies above.	Yes
Pedestrian Realm Interface - Transition (11.1.53)	Building and landscape design should create clearly delineated transitions from the public realm to the private. At each transition, consider how layers of planting and/or grade change can be utilized to provide the appropriate balance of privacy and sociability.	12' setback allows a front yard to be larger private patio spaces with terraced landscape buffers to provide privacy. Access paths with gates from the patio to the sidewalk are also provided. The private patios are designed 2' to 4' higher than the sidewalks, that way residents sitting on the patios can overlook the public while the public can enjoy the terraced landscape buffer without interrupting the private activities. At this time, the design team hasn't received further information regarding the greenway from the city. An animated frontage design with terraced landscape buffers and connection paths has been provided to support the greenway. Refer to above.	Yes
Greenways (14.1.4)	LOR: A future greenway is proposed on West 6th Avenue. Considering opportunities for improved pedestrian scale, connection, access and activation along the frontage.	A greenway for cycling separated by the landscaped boulevard from the pedestrian sidewalk has been indicated in the renders.	Yes

REZONING POLICY COMPARISON

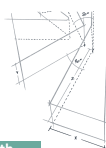

	Broadway Plan Policy Letter of Response	Proposed Development	Conforming with Broadway Plan and Municipal Responses
Parking and Loading (11.1.65)	Parking entries, loading and service facilities should be located at the lane. Where lane access is not available, these elements should be located to minimize impact on key pedestrian and cycling connections and frontages.	Access to parking and loading are located off the side lane and back lane.	Yes
Enhanced Open Space Setback (11.4.11) Also refer to Broadway Public Realm Plan (1.4.1 to 1.4.4, 1.5.1 to 1.5.9)	Development on larger sites with a frontage of 60.7 m (199 ft.) or greater should provide an at-grade Enhanced Open Space Setback (EOSS), utilizing additional building height (per 11.4.4) to reallocate density. The EOSS should comprise approximately 20% of the frontage length that extends the full depth of the site. This space is intended primarily for publicly accessible greenspace and park-like space. Other uses may be considered on a case-by-case basis (e.g. outdoor child day care spaces). See the Broadway Public Realm Plan for further design guidelines for EOSS.	The site offers approximately 4,200 sq ft of Enhanced Open Space , located at the central front and west. The central area contributes 78 feet (20%) of frontage , while the west adds another 19 feet 8 inches (5%) . This combined effort results in an overall frontage open space of approximately 25.8% , surpassing the recommended 20%.	Conforms with City Suggestions.
Min Lot Depth (11.4.6)	110 ft., rear laneway required	120 ft., no rear laneway available	Yes
Front Yard Setbacks (11.4.7)	Front yard setbacks should be a minimum of 3.7 m (12 ft.).	12 ft. setback provided for aboveground	Yes
Underground Parking Setbacks (11.4.8)	Underground parking structures should set back from the front property line to ensure adequate soil depth for healthy trees.	12 ft. setback provided for underground	Yes
Side Yard Setbacks (11.4.9)	Side yard setbacks for the podium should be a minimum of 3.7 m (12 ft.).	40 ft. side yard setback provided to support the building separation between the 22-story tower and the potential 12-story mid-rise in the adjacent sites	Yes
Rear Yard Setbacks (11.4.10)	Rear yard setbacks should allow for usable ground floor outdoor space, support the liveability of residential units, and consider solar access and overlook for adjacent properties.	40 ft. rear yard setback provided to support 80 ft. tower separation	Yes
Tower Floorplate (11.4.12)	For lot depths of 36.6 m (120 ft.) or greater, maximum tower floor plates of 604 m ² (6,500 ft. ²) are recommended.	To achieve the setback requirements and podium height max, city staff advised a larger tower floor plate will be considered to achieve 6.5 FAR. Therefore 6,908 sq. ft. of tower floor plate is provided.	The larger floor plate of 6,908 sf. is to achieve the 40' setback at West, East and South property lines, conforms with City Suggestions.

	Broadway Plan Policy Letter of Response	Proposed Development	Conforming with Broadway Plan and Municipal Responses
Ground Floor Units Outdoor Space (11.4.16 and 11.4.17)	Where possible, ground floor units should open onto usable outdoor space. Where ground floor units are accessed primarily from an interior corridor, outdoor spaces should be designed as 'backyards' with improved privacy screening and more generous dimensions.	All ground floor units will have usable outdoor space. A generous patio with landscaped backyards is provided for all the ground units. Separate gates and privacy fences at the backyards are provided to connect with the adjacent sidewalks or common paths.	Yes
Outdoor Amenity Space (11.4.18)	Shared outdoor amenity space should be provided at the ground floor, podium and/or rooftop LOR: For Residential rental projects, with below market component, a minimum 2.7 sq. m (29 sq.ft.) per dwelling unit of common outdoor amenity is encouraged.	17,145 sf. of shared amenity spaces are provided at ground, podium rooftop and tower rooftop. This is equivalent to about 41 sf per unit, which is much larger than the minimum area recommendation of 29 sf. per unit.	Yes
Indoor Amenity	LOR: A minimum of 1.2 sq. m (13 sq.ft.) per dwelling unit of common indoor amenity areas is strongly recommended.	We've allocated 9,668 square feet for indoor amenity spaces . This includes: 7,091 square feet for recreational areas. 165 square feet for the leasing office. 2,412 square feet for amenity services and amenity circulation. This averages out to 23.2 square feet per unit , significantly exceeding the recommended minimum of 13 square feet per unit.	Yes
Solar Access	Proposed new development should not create new shadow impact on parks and public school yards from the spring to fall equinoxes between 10AM and 4PM.	The proposed development will have no shadow impact on parks or public schoolyards from the spring to fall equinoxes between 10 AM and 4 PM Note the neighbor's development at 2267-2275 W 7th Ave has a significant shadow impact on the proposed west tower at 2280 West 6th Ave from 10:20 AM and lasts about 5.5 hours on March 20th, from L1 to L14.	Yes
Solar Access - Children's play (11.4.19)	A portion of the shared outdoor amenity space should be designed to support children's play with a focus on flexible features, innovative play spaces, and exploratory structures.	The children's play has been located at the lobby rooftop. As shown from the shadow study from 10 AM to 1 PM, 3 hours, more than a minimum of 2 hours of solar access are achieved on December 22. After 1 PM, the development at 2267-2275 W7th Ave starts casting a shadow on the podium roof.	Yes

POLICY CONTEXT

Housing Policies

Affordable Housing Policies

The affordable housing policies - approved in 1989 - are a group of policies that encourage the development and distribution of affordable housing developments throughout the City of Vancouver. Rather than concentrating affordable housing developments in a few areas of the city (i.e. Downtown Eastside) the policies promote these forms of development equally across all communities.

Project Response

The development and implementation of the Broadway Plan encourage the provision of affordable housing in a significantly greater area of the city than previously contemplated.

This project contributes to a significant increase in the supply of rental housing in Vancouver, improving the quality of rental housing stock, particularly in the Kitsilano neighborhood/Broadway Area. It also expands the type and size of affordable housing available in the city.

Vancouver Housing and Homelessness Strategy & The Housing Vancouver Strategy

The strategy discusses the housing continuum within the City of Vancouver and suggests a mission to create a city of communities which cares about its people, its environment, and the opportunities to live, work and prosper (City of Vancouver, 2011). Goals promoted by the strategy are to end street homelessness, provide and increase in affordable housing choices for all citizens within the city.

The Housing Vancouver Strategy (2018 - 2027) builds upon Vancouver's Housing and Homelessness Strategy from 2011, providing a renewed vision and policy direction with strategies and actions aimed at addressing Vancouver's affordability crisis.

Key objectives within the strategy include;

- Shift toward Right Supply
- Action to Address Speculation, Protect and Support Diversity
- Protect our Existing Affordable Housing for the Future
- Renew our Commitment to Partnerships for Affordable Housing
- Align City processes with housing targets

The document suggests various strategies aimed at addressing housing demand, identifying the right supply, strengthening partnerships, indigenous housing and wellness, preventing homelessness, retaining existing rental, and supporting renters.

Project Response

The proposed project meaningfully addresses many of the aspects identified above, including:

- Provision of affordable housing, addressed through inclusion of 20% of residential floor area at below-market rental rates
- Tenant relocation and protection in accordance with the guidelines set out in the Broadway Plan

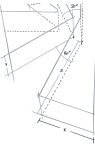

POLICY CONTEXT

Sustainability and Building Performance

Urban Agriculture Guidelines

These guidelines are intended to provide guidance to proponents on the design of urban agriculture installations where proposed. They are also to be used by city staff in assessing the merits of these proposals.

Urban Agriculture is an overarching term referring to a range of activities that are related to growing plants for food and other uses, within or surrounding cities or towns. The City of Vancouver identifies community gardens, farmers markets, hobby bee-keeping, shared garden plots and edible landscaping.

Goals for encouraging urban agriculture include; increasing the City's food security while reducing the City's ecological footprint, encouraging social interaction and community growth and supporting environmental and socially sustainable activities.

Project Response

The extensive variety of outdoor green spaces and amenity areas provides significant opportunities for urban agricultural use. With green spaces distributed across grade-level perimeter setbacks, the lobby rooftop, and the tower rooftop (accessible via two amenity spaces at the top of the tower), these areas are thoughtfully designed with diverse qualities of space and light to accommodate a wide range of uses.

- The multi-sports court and dog run, located at ground level, benefit from the shade provided by the neighboring development at 2267-2275 West 7th Avenue, creating a comfortable environment for activities and pet recreation.
- The children's play area and urban agriculture space on the lobby rooftop enjoy abundant sunlight between the towers, making it ideal for both active play and gardening.
- The outdoor spa and dining spaces on the tower rooftop offer breathtaking west-facing views of sunsets and mountains, creating a serene and picturesque setting for relaxation and social gatherings.

Family Room: Housing Mix Policy for Rezoning Projects

Among the objectives of this policy are that in developments that include a mix of household types, family units should be grouped together in the most appropriate parts of the building or site, located overlooking outdoor areas, with an appropriate amount of open space to meet the needs of children and adults. The policy also provides direction as to appropriate unit and room sizes.

Also included are policy directions that require 35% of units provided to be family size (defined as having two or more bedrooms). Specifically, the governing Policy #2 requires that rezoning applications for secured market rental projects are required to include a minimum of 35% family units with two or more bedrooms; this policy does not require a minimum percentage of three-bedroom units. Alternatively, Policy #1 applies to residential strata housing projects which requires a minimum of 35% family units including a minimum of 10% three-bedroom units and a minimum of 25% two-bedroom units.

Project Response

The size and layout of the family-sized two- and three-bedroom units are designed to balance optimal function and usability while maintaining affordability. These unit sizes comply with the requirements of this policy and align with the City of Vancouver Housing Design Guidelines.

The proposed development provides 44% family-friendly units, including 10% of the total units as three-bedroom units.

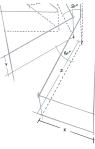

PROJECT THEMES



Responding to a Housing Crisis

This project is based on the net addition of 327 secured rental apartments, with at least 20% of the 416 units designated as below-market rentals.



Cycling Infrastructure and Amenities

The project actively promotes cycling through the provision of numerous secure bicycle parking spaces, accessible via two dedicated bicycle ramps. Additionally, it includes enhanced cycling amenities such as a repair station and a tool library.



Activated Public Realm

Recognizing the vibrancy of the Kitsilano neighborhood, the project enhances the public realm by providing street-front access to ground-oriented units, contributing to a lively and engaging streetscape.



Private and Shared Outdoor Amenity Spaces

The design prioritizes access to a variety of outdoor spaces for residents. This includes semi-private ground-level outdoor areas facing the street front and rear yard, as well as lobby rooftop and rooftop amenity spaces. Furthermore, tower units feature spacious, covered balconies, ensuring all residents have access to functional and livable outdoor areas.



Active Transportation in Place of Parking

Kitsilano is well-served by multiple public transit options, including bike lanes, the new SkyTrain line, and extensive bus routes. Accordingly, the project reduces on-site parking in favor of supporting this mature active transportation infrastructure.

Sustainable, Community-Oriented Approach

The project adopts a sustainable and community-focused approach to secured market rental housing, creating shared spaces designed to foster interactions and gatherings. Features include a sports court, dog run, gardens, and a playground, all contributing to a sense of community.



03 REZONING RATIONALE

03.1 Building Height

BUILDING HEIGHT

The proposed development consists of 22 stories of residential apartments, an additional story for amenity and mechanical rooms, and another floor for the elevator penthouse. According to the Zoning Bylaw, the amenity level, mechanical rooms, and elevator penthouse are exempt from the building height calculation. As a result, the total building height is 22 stories, measuring 74.52 meters (244.6 feet) from the base surface at 40.085 meters (131.6 feet) to the top of the roof finish of the highest residential floor, L22, at 113.54 meters (372.6 feet). The floor-to-floor height for both the amenity level and the elevator penthouse is 16 feet, adding 32 feet above the residential floors. The building's highest point reaches 125.04 meters (410.3 feet).

The development features a level 1 floor-to-floor height of 20 feet to accommodate the main lobby, indoor gym in the central area, and loft units on either side. The mezzanine level, L1.1, is not counted as a story as it occupies less than 40% of the horizontal plane separating the mezzanine from the floor below. The mezzanine level complies with all relevant VBBL requirements regarding travel distance, size limits, and percentage limits.

The project assumes 10-foot floor heights for the residential floors and 16-foot heights for the amenity floors. The loft units provide a clear headroom of 8 feet 4 inches (2.54 meters) for both the loft and the space below. The ground floor double-height area, including the lobby and gym, features a clear headroom of 19 feet 4 inches (5.893 meters).



NORTH ELEVATION SCALE 1:300



03 REZONING RATIONALE

03.2 Site Design

LANE DESIGNATION

Scale 1:300

The proposed development includes a 6.1-meter (20-foot) side lane dedication along the east property line and a 3.1-meter (10-foot) lane dedication along the south property line. Combined with a 3.1-meter (10-foot) lane dedication along the south neighbor's property lines, this creates a 20-foot rear lane, with half situated within the property and the other half outside it.

Similarly, the neighboring property at 2267-2275 West 7th Avenue is required to dedicate a 20-foot side lane along their west property line. The rear lane will seamlessly connect to the side lanes at both the east and west ends via 45-degree chamfers, as recommended by the project engineer.

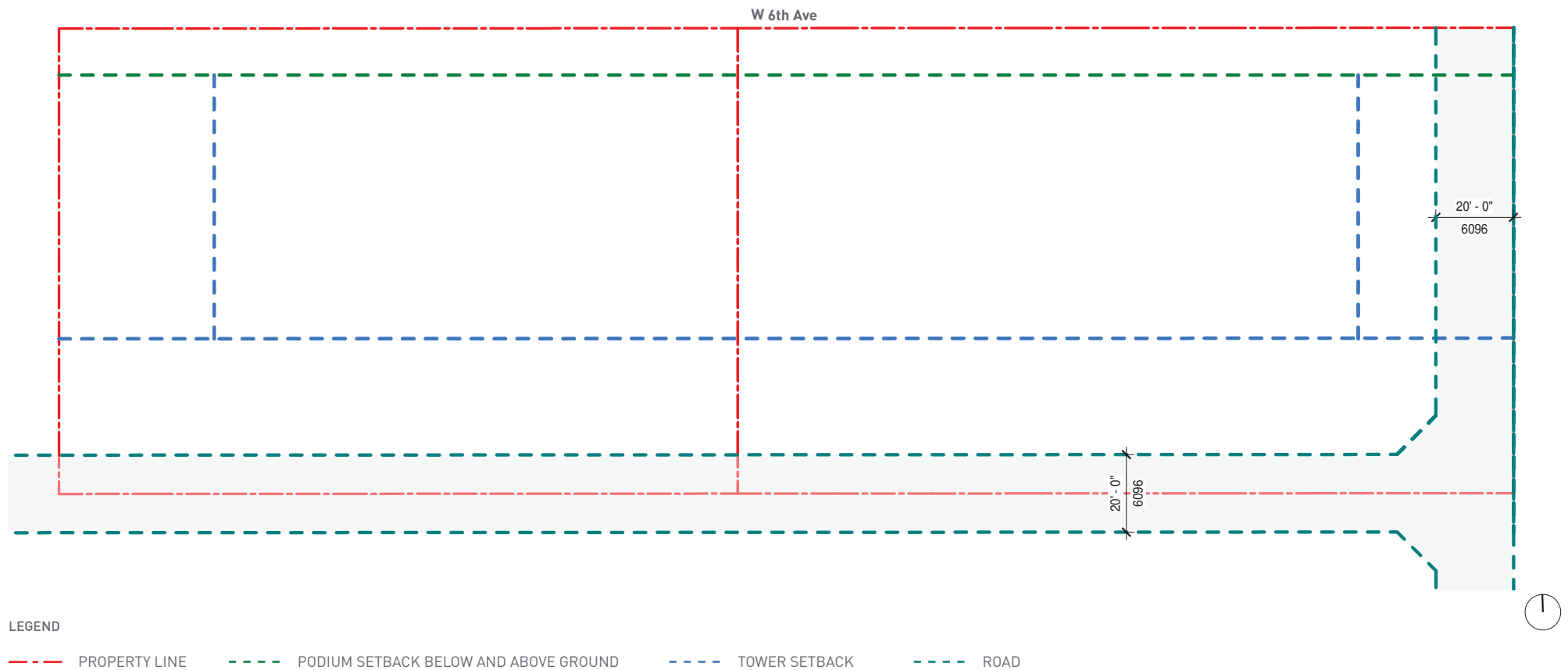

DENSITY + SETBACKS

Scale 1:300

The proposed development provides a total floor area of 27,169 s.m. (292,448 s.f.), and a density of 6.5 FSR, which meets the Density requirement from the Broadway Plan.

Front Yard: The proposed development provides a 3.7-meter (12-foot) front yard setback on West 6th Avenue for both below-grade and above-grade components. No underground parking will encroach on the front yard. The setback areas are clear of any encumbrances, except for planters and entry paths for the ground-floor units. Passive rainwater management and sufficient growing medium are provided for tree retention and the urban tree canopy.

Side Yard: The proposed development provides a 12.19-meter (40-foot) side yard setback on both the west and east property lines, which includes the 6.1-meter statutory right-of-way for the side lane at the east property line. Underground parking will utilize the space under the setback but will not encroach on the designated lane. The two towers will be separated by 81 feet.

Rear Yard: The proposed development provides a 12.19-meter (40-foot) back yard setback on the south property line to comply with the 80-foot tower separation to the development at 2267-2275 West 7th Avenue. Underground parking will utilize the space under the setback but will not encroach on the designated lane.

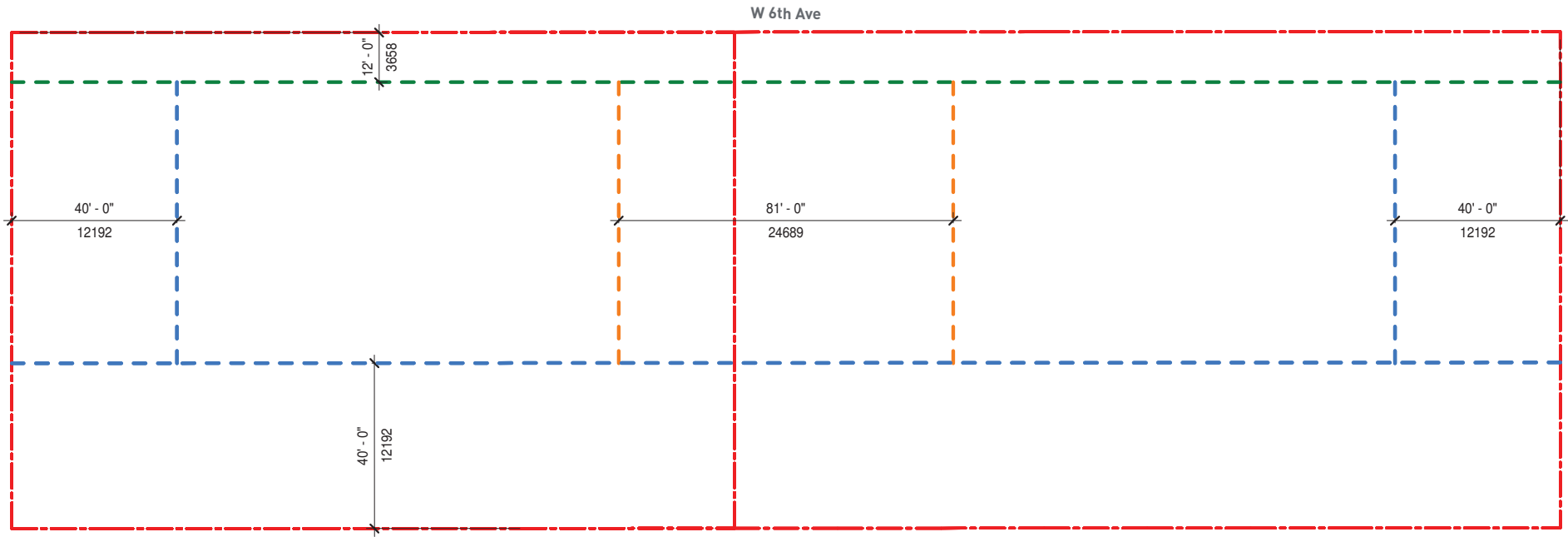

LEGEND

- PROPERTY LINE
- PODIUM SETBACK BELOW AND ABOVE GROUND
- TOWER SETBACK
- TOWER SEPARATION



TOWER SEPARATION

Scale 1:400

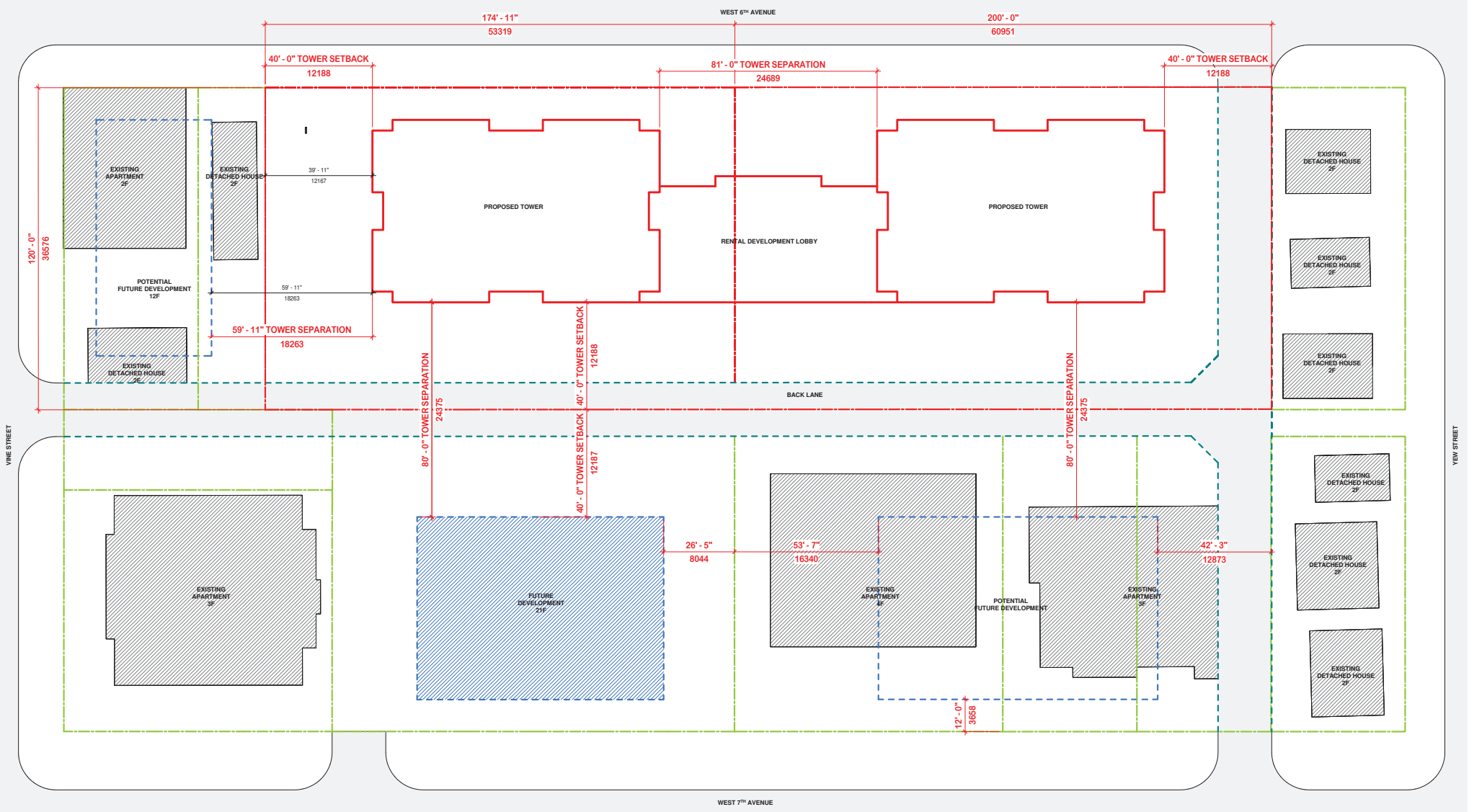

SHADOW STUDY

The current design provides the shadow study conducted from 10 AM to 4 PM on the Spring Equinox, Fall Equinox, and June Solstice.

A shadow study was also conducted on the Winter Solstice to ensure the children's play area meets the minimum two-hour sunlight requirement. Based on the shadow study, the children's play area is located on the lobby rooftop.

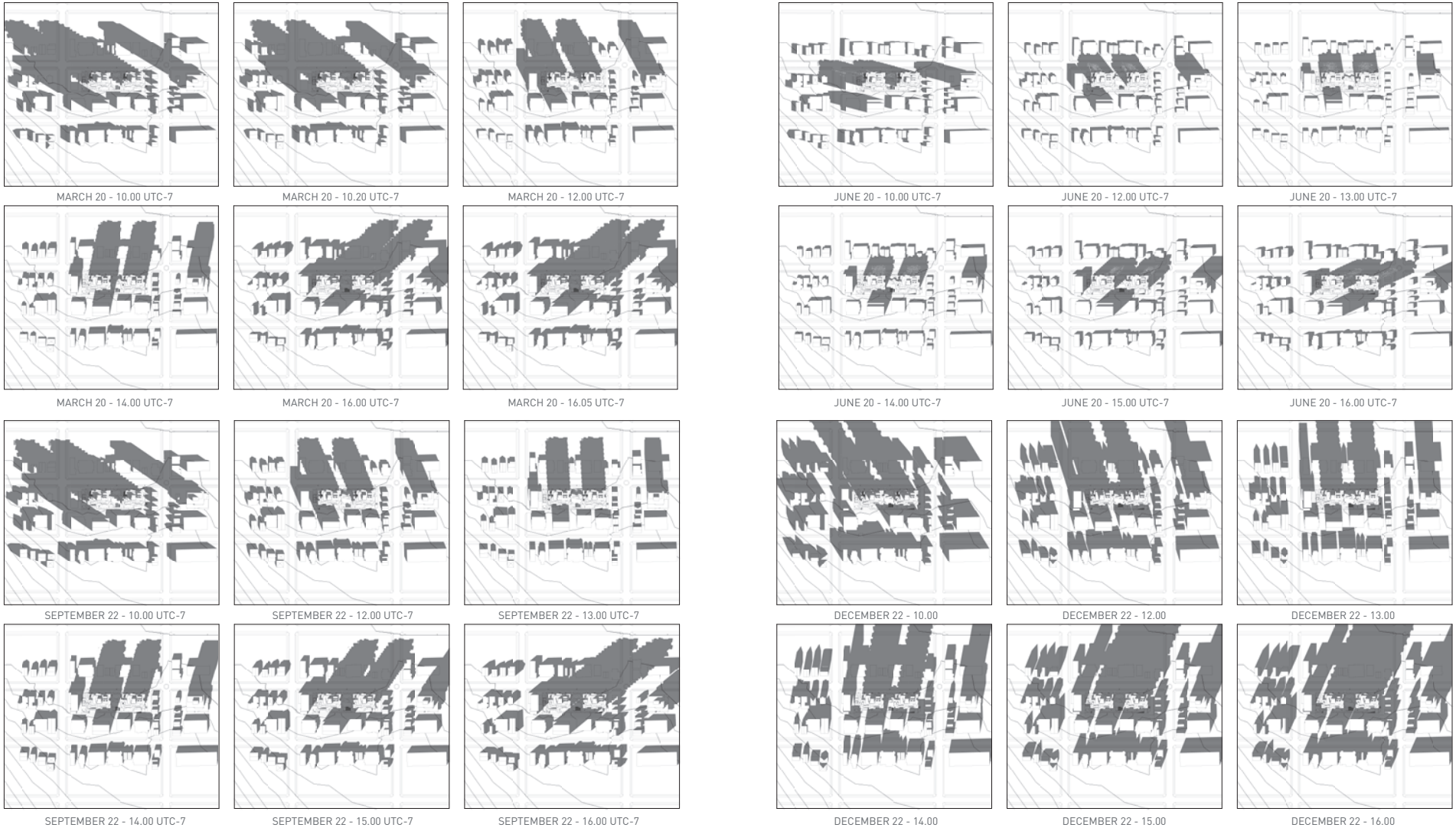
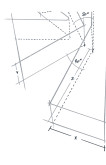

TREE RETENTION

According to the arborist report, there are 25 on-site trees, all of which will require removal and replacement to accommodate demolition, lane dedications, and development.

All eight off-site street trees located on City property along West 6th Avenue will be preserved. However, one tree on the neighboring property to the east (2221 Yew Street) and one tree on the neighboring property to the south (2225 West 7th Avenue) will need to be removed to facilitate the lane dedications.

City staff has indicated that a future greenway is planned for West 6th Avenue. In support of this initiative, the proposed development includes a 12-foot setback along West 6th Avenue for both above-ground and underground components. This setback contributes to passive rainwater management and ensures sufficient growing medium for new plantings, aligning with the City's green infrastructure goals.

Ownership	Total	Removed	Protected
On-site Trees	25 39 inc u/s)	25 (14 u/s)	0
City Street Trees	8 (2 prev removed) (1 adjacent)	0	8
Off-site Private Trees	3	2	1
TOTAL	36	27	9

LEGEND

- - - - PROPERTY LINE
- TREES TO BE RETAINED
- TREES TO BE REMOVED

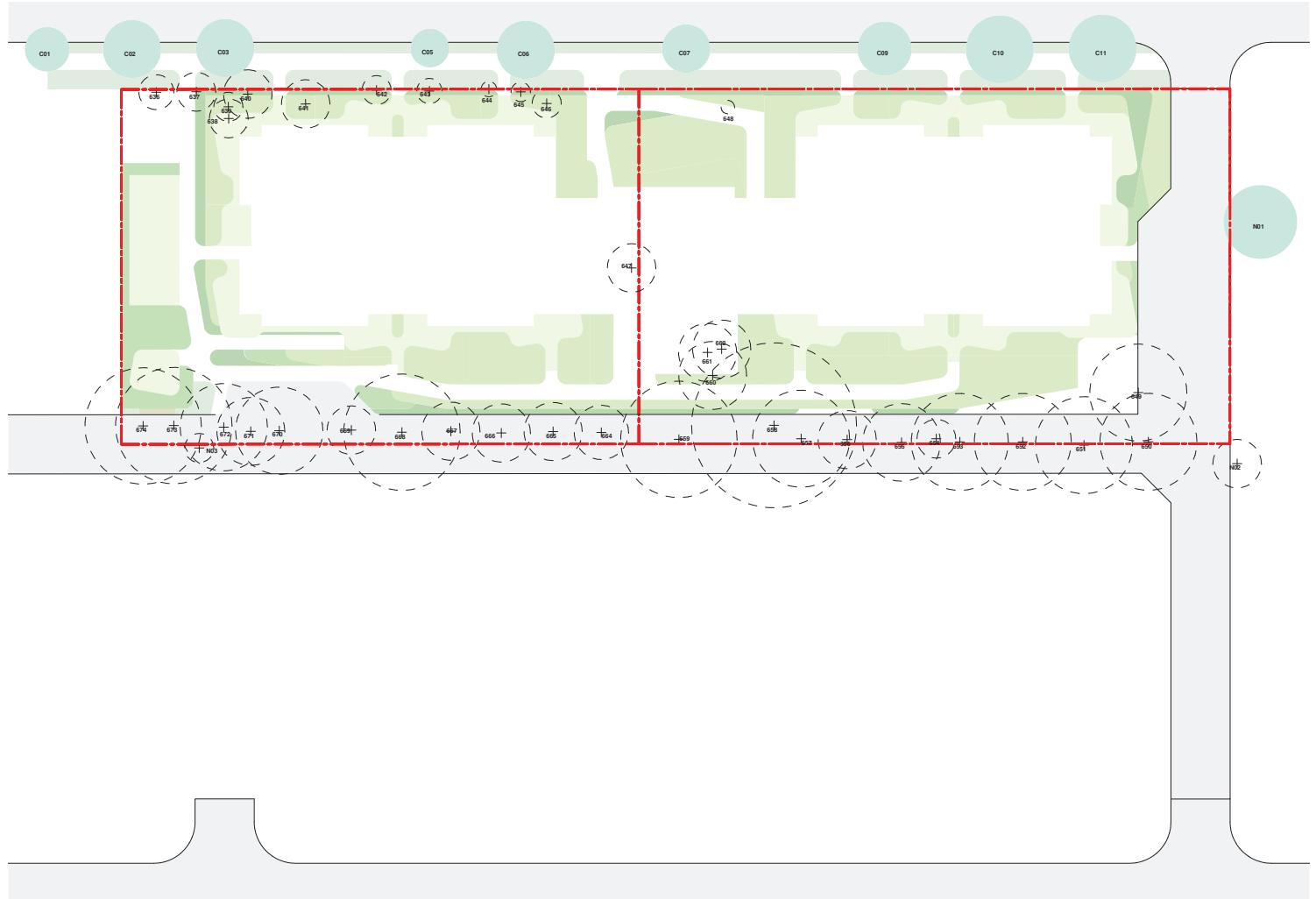

BUILDING GRADE

The site has a gentle slope, rising from the lowest point of 39.10 meters (128 feet 3 3/8 inches) at the southeast corner of the back lane to the highest point of 40.71 meters (133 feet 6 3/4 inches) at the northwest corner along West 6th Avenue.

The total height difference across the site is approximately 1.61 meters (5 feet 4 inches), which is about half the height of a typical floor.

Based on the average grade, the base surface elevation is 40.085 meters (131 feet 6 inches).

EXISTING AVERAGE GRADING (IMPERIAL)											
1-2	(40.220	+	39.100)	/2=	39.660	x	36.59	=	1451.12
2-3	(39.100	+	40.310)	/2=	39.705	x	114.26	=	4536.77
3-4	(40.310	+	40.710)	/2=	40.510	x	36.58	=	1481.69
4-1	(40.710	+	40.220)	/2=	40.465	x	114.26	=	4623.33
									301.68		12092.91
EXISTING AVERAGE GRADING (IMPERIAL)										40.085	

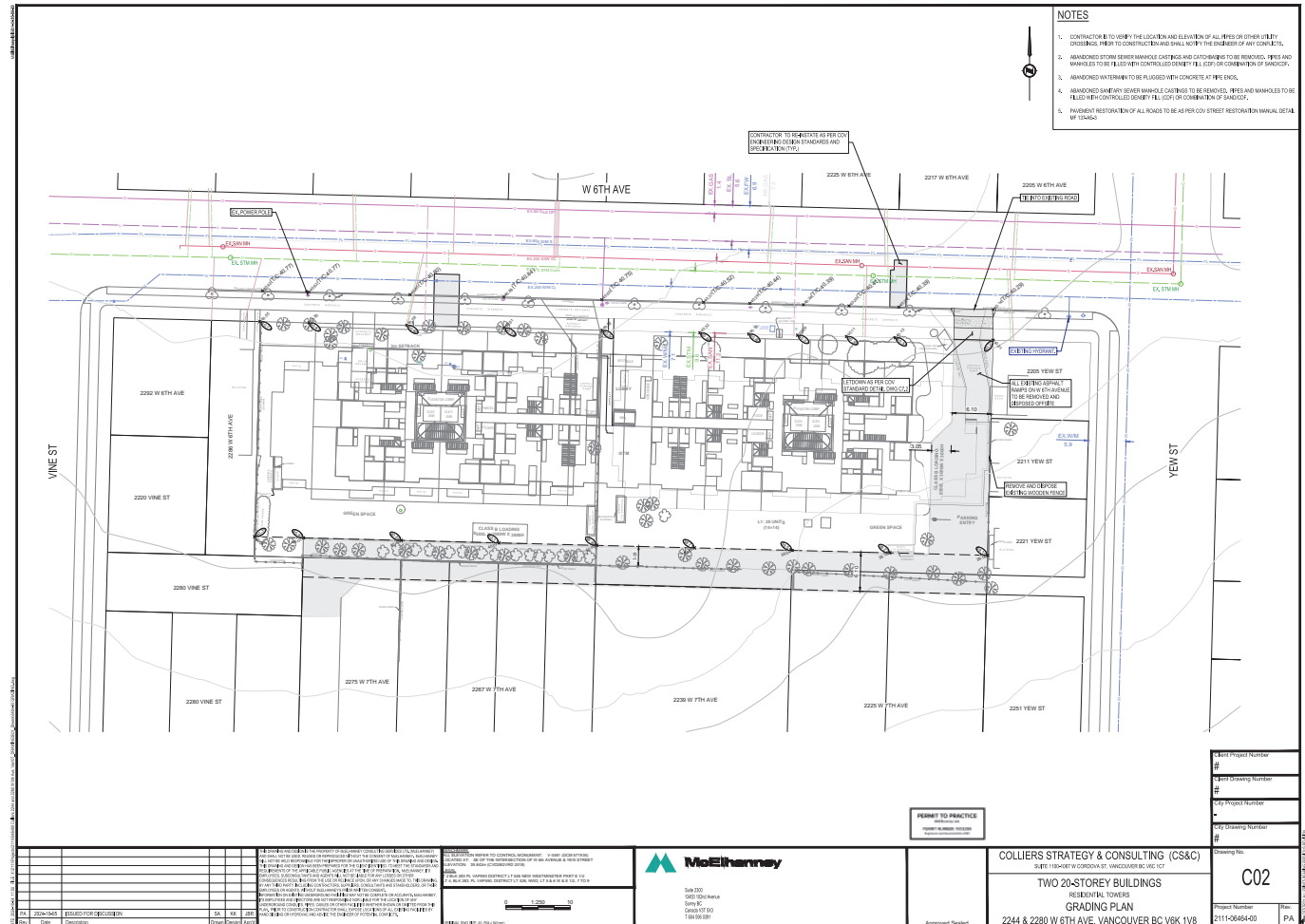



03 REZONING RATIONALE

03.3 Pedestrian Realm Interface

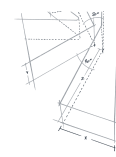

GRADING STRATEGIES

The design incorporates a 3-5 foot grade separation between the private patios and West 6th Avenue. This elevation enhances security for private spaces, reduces noise intrusion, and improves privacy through a landscaped buffer.

Raising the first level offers multiple functional and design benefits:

1. Bicycle Storage and Accessibility:

The elevation allows for the creation of a dedicated mezzanine level accommodating all required bicycle storage, plus an additional 30% to comply with TDM Plan B strategies. This cycling mezzanine is conveniently accessible via two short ramps—one per tower—from the side and rear lanes. Additionally, the mezzanine benefits from natural light, enhancing the user experience.

2. Concealed Loading and Parking:

Class A loading and Class A passenger parking spaces are discreetly located beneath the east tower and sheltered by the parkade roof. This design minimizes visual and weather exposure, optimizing outdoor green spaces at grade and enlarging private patios and backyards for ground-level residential units.

3. Enhanced Landscaping and Utilities:

The additional 4-foot depth above the first parking level, outside the towers and podium, provides space for planting trees and accommodating service lines, further supporting green infrastructure and landscape integration.

ENHANCED OPEN SPACE SETBACK - MAIN ENTRY

The proposed development thoughtfully addresses the upgraded outdoor sidewalk elevations. Based on the average site grading, the first level is set at an elevation of 136'-0", which is 4'-6" higher than the base surface.

The main entrance lobby is centrally located within the building, fronting West 6th Avenue. A ramp at a 8.3% slope connects the building entrance to the existing sidewalk, ensuring accessibility. The ramp is carefully screened with landscaping to soften its appearance and seamlessly integrate it into the overall streetscape design.

Main Entry - Northwest



Private Patios - East Tower



PEDESTRIAN REALM INTERFACE - PRIVATE PATIOS



The proposed development terraces the ground-floor elevations from the private patios to the adjacent sidewalk, maintaining a maximum step height of 2 feet. This terracing creates a landscaped buffer, enhancing privacy and separation between the residential patios and the public realm.

Steps and gates will be incorporated to provide direct access from the ground-level residential units to the pathway along the back lane, ensuring both functionality and connectivity.

Private Patios - Southeast



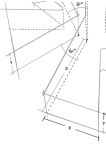

03 REZONING RATIONALE

03.4 Livability

LIVABILITY - PRIVATE OUTDOOR SPACE

The balconies alternate directions on every other floor, adding visual interest to the building form, increasing sunlight penetration into habitable spaces, and enhancing livable areas.

The proposed development provides enlarged private outdoor spaces that exceed the minimum 2.7 square meters (29 square feet) required. These include private patios for ground-level and podium-roof-level units, as well as private balconies for all other units:

Private Patio sizes:

- Average size: 37 square meters (402 square feet).
- One-bedroom units: 121 to 204 square feet.
- Two-bedroom units: 200 to 697 square feet.
- Three-bedroom units: 464 to 699 square feet.

Private Balcony sizes:

Minimum depth: Exceeds the required 6 feet, with a maximum depth ranging from 8 feet 6 inches to 9 feet 6 inches depending on location.

- Average size: 13.4 square meters (145 square feet).
- Studio units: 120 square feet.
- One-bedroom units: 87 to 168 square feet.
- Two-bedroom units: 208 to 241 square feet.
- Three-bedroom units: 60 to 241 square feet.

These well-designed private outdoor spaces contribute significantly to the livability and functionality of each unit, providing residents with generous outdoor areas for relaxation and recreation.

Podium Patio



Private Patio



LIVABILITY - PRIVATE OUTDOOR SPACE - GROUND LEVEL

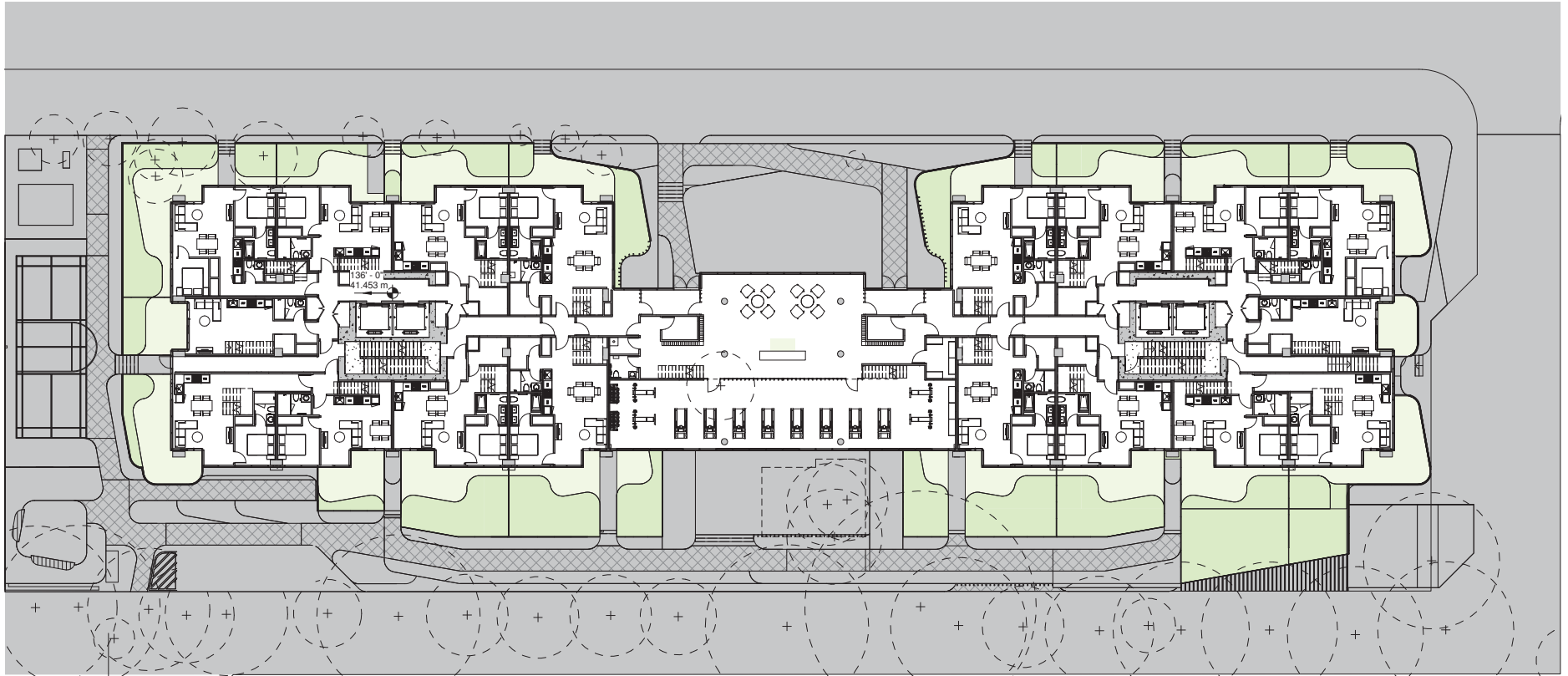
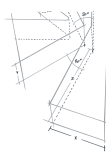

LEGEND

- PRIVATE PATIOS
- PRIVATE YARDS





03 REZONING RATIONALE

03.4 Parking and Loading

PARKING AND LOADING - VEHICLE PARKING ENTRY

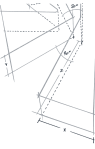

As per feedback from the LOE letter, the new development provides a parking entry off the side lane at the lowest corner of the site. The ramp is designed with a 12.5% slope, a 10% transition zone at the beginning and end of the ramp, and a subsequent 5% slope connecting to the first parking level.

Parking Entry



PARKING AND LOADING - BICYCLE PARKING ENTRY



The development includes two separate bicycle parking entry points, strategically positioned to ensure ease of access and functionality. One entry is located at the east tower adjacent to the vehicle parking entry, while the other is at the west tower near the loading bay.

Both bicycle parking entry ramps are fully accessible, designed with a gentle 8.3% slope. These ramps also provide seamless connections between the loading bays, elevators, and garbage collection rooms, enhancing overall accessibility and operational efficiency.

Bicycle Entry - West Tower



Bicycle Entry - East Tower



PARKING AND LOADING

Class A Loading

Two Class A loading spaces (2900 W x 5500 L) are provided on the first parking level at elevations of 120 feet to 123 feet.

The Class A loading spaces are accessible parking spaces with a 1.5-meter-wide accessible path along the full length of the parking space. An accessible path connects the Class A loading area to the elevator lobby of the podium.

Class B Loading

Two Class B loading spaces (10200 L x 3400 W) are provided off the lane: one at the east tower side lane, and the other at the west tower back lane.

The Class B loading spaces are arranged parallel to the lane to allow easy access for service trucks.

The Class B loading spaces are fully set back from the lane to allow bypass traffic while trucks are servicing the building.

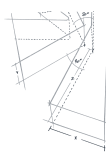

Class A Loading - P1.1

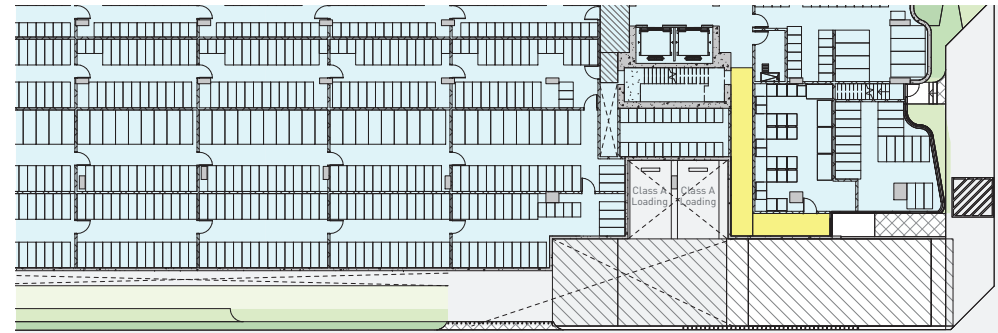

Class B Loading - East



Class B Loading - West





04 DESIGN RATIONALE

04.1 Indoor and Outdoor Amenity

AMENITY ANALYSIS

The development features a total of **9,668 square feet of indoor amenity space**.

This includes:
7,091 square feet for recreational use, encompassing the lobby, gym, co-working areas, spa, dining, and lounge.
165 square feet for the leasing office.
2,412 square feet for amenity services, such as universal bathrooms, janitorial facilities, mail rear load areas, a parcel room, and service circulation.

We anticipate that this indoor amenity space will be **exempt from the Floor Area Ratio (FAR)**. On average, the development provides **23.2 square feet of indoor amenity space per unit**, which is **10.2 square feet above the recommended minimum standard of 13 square feet per unit**.

Additionally, the development offers **17,145 square feet of outdoor amenity space**, equating to approximately **41 square feet per unit**. This is well over the minimum recommended area of **22 square feet per unit**, further enhancing the livability and recreational opportunities for residents.



LEGEND

- INDOOR AMENITY
- OUTDOOR AMENITY

AMENITY ANALYSIS

Enhanced Open Space Areas

The enhanced open space is divided into two key areas: a central portion and a western portion.

Central Area:

To maximize the central enhanced open space, the shared lobby is set back 15 meters from West 6th Avenue. This area spans 78 feet in length and 49 feet (15 meters) in depth, contributing around 2,500 sq ft of open space, complete with a landscape seating area.

Western Area:

At the west of the site, an additional 1,700 sq ft of open space is provided, measuring 19 feet 8 inches long and 83 feet deep. This area features both a multi-sports court and a dog run.

In total, approximately 4,200 sq ft is dedicated to the enhanced open space.

Enhanced Open Space Frontage

The 20% open space frontage requirement is met by the 78 feet of frontage located at the center of the site. With an additional 19 feet 8 inches of frontage at the west, the total open space frontage is approximately 25.8%.

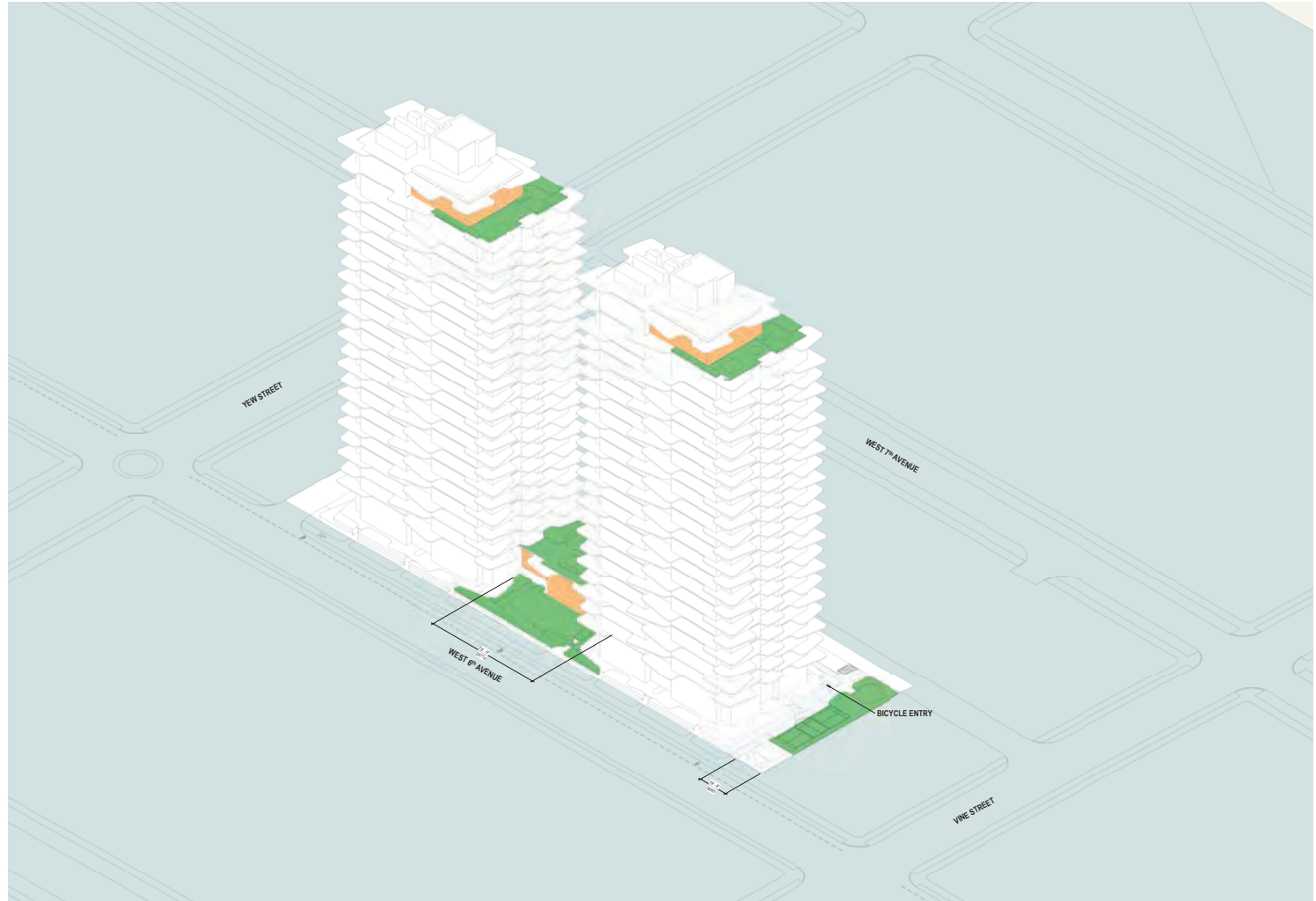

LEGEND

- INDOOR AMENITY
- OUTDOOR AMENITY

RESIDENTIAL OUTDOOR AMENITY - EAST TOWER ROOFTOP

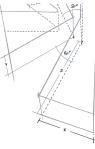

Exterior amenities feature outdoor dining, BBQ areas, and outdoor lounges with entertainment fire-pits, all oriented west towards the sunset.

Several flexible group seating areas are provided to accommodate various groups of people. The outdoor furniture can be rearranged to suit the needs of special large events.

Other daytime activities, such as outdoor games, are oriented south to enjoy the sunlight. The outdoor space could potentially be converted into an outdoor cinema in the evening.

BBQ Dining - East Amenity Tower



Outdoor BBQ - East Amenity Tower



RESIDENTIAL OUTDOOR AMENITY - WEST TOWER ROOFTOP



The spa and wellness amenities are situated in the west tower, thoughtfully oriented to the west to capture stunning sunset views.

Outdoor spa features include an 8-10 person hot tub and a cozy 2-person cold plunge pool, positioned adjacent to a relaxation lounge equipped with a fire-pit, comfortable seating, and loungers for ultimate comfort.

The amenity level is further enhanced with windscreen installations and trellis structures, offering weather protection and ensuring year-round usability.

Hot Tub - West Amenity Tower



Outdoor Spa - West Amenity Tower



RESIDENTIAL OUTDOOR AMENITY - LOBBY ROOFTOP

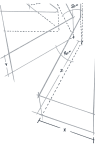

The lobby rooftop is designed as a vibrant amenity space for children's play, featuring interactive play structures suitable for all age groups, including adults.

The children's play area and urban agriculture space on the podium rooftop enjoys abundant sunlight between the towers, making it ideal for both active play and gardening.

Additionally, this rooftop serves as a circulation hub, providing seamless connectivity between the towers for easy access to shared amenities.

Children's Play



Children's Play



RESIDENTIAL OUTDOOR AMENITY - OUTDOOR GYM



An outdoor deck extends seamlessly from the indoor gym, featuring a leveled floor finish to strengthen the indoor-outdoor connection. This south-facing outdoor gym is enhanced with a pergola, offering the flexibility to enjoy sunlight while providing shade and weather protection during the rainy season. The space is ideal for outdoor yoga and other mat-based exercises, ensuring year-round usability.

Outdoor Gym - Southeast

Outdoor Gym - Southwest



RESIDENTIAL OUTDOOR AMENITY - DOG RUN + SPORTS COURT



A dog run is located in the southwest corner of the site, featuring grassland, seating areas, and trees to create a comfortable and functional space for pet owners.

An accessible common path connects to the dog run, while a landscaped buffer separates it from private patios, ensuring privacy and a clear division between shared and private spaces. Additionally, a landscape buffer is provided to screen the adjacent neighboring property.

In the northwest corner, a small multi-sport court offers opportunities for activities such as badminton and basketball, enhancing the recreational amenities available on-site.

MULTI-SPORT COURT



DOG GARDEN



RESIDENTIAL INDOOR AMENITY

An indoor gym (1,499 square feet) is located on the ground floor, directly facing the main lobby. A mezzanine (1,129 square feet) is located on the upper level and can be accessed via either the internal stairs or the elevator in the west tower. The main indoor amenity space is located on the tower rooftop (L23) and is divided into two major functions: one for social spaces in the east tower and the other for wellness and coworking in the west tower. Both indoor amenities are oriented north and west to enjoy views of the North Shore Mountains and sunsets.



L1 Floor Plan

L1.1 Floor Plan

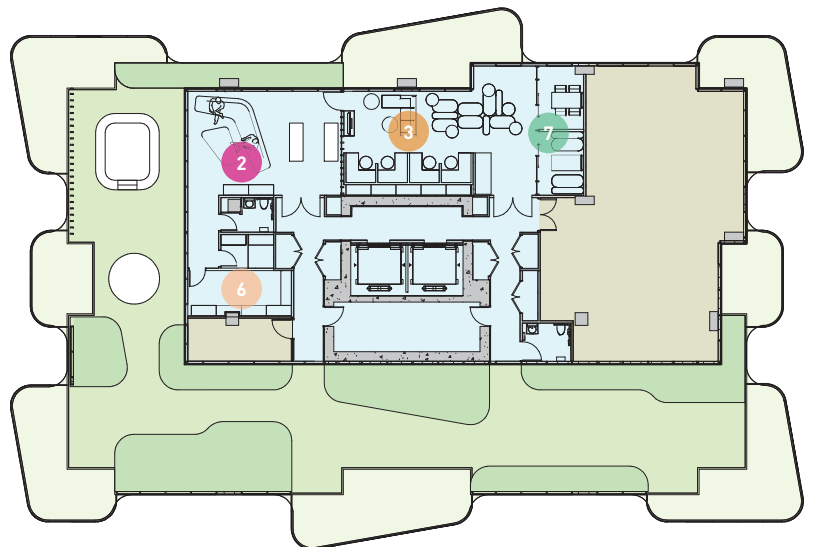

L23 Amenity

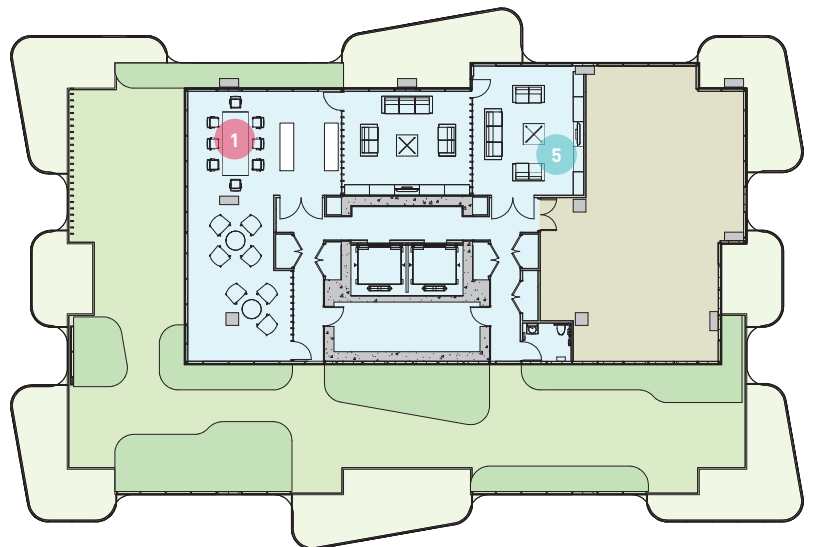

RESIDENTIAL INDOOR AMENITY

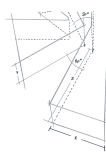

East Tower Rooftop: Social Space

- 1
- 5

The dining and lounge areas are located in the northwest corner of the east tower, offering stunning mountain and ocean views, as well as breathtaking sunsets—ideal for evening use. The indoor dining and entertainment kitchen is strategically placed to maximize connectivity with the adjacent outdoor dining deck, creating a seamless indoor-outdoor experience. A games lounge, situated next to the social lounge, faces north to fully embrace the mountain views, enhancing the rooftop's appeal as a vibrant gathering space.



1. Dining and Lounge



5. Games Lounge

West Tower Rooftop: Wellness

- 2
- 6

The wellness area on the west tower rooftop is oriented westward to capture serene sunset views. Amenities include outdoor hot and cold tubs with a service counter, an indoor meditation room, a cool-down lounge, and a sauna. A dedicated entry corridor, separate from the main circulation, ensures privacy and convenience for spa users. This corridor connects to a rinse shower, a universal change room with a shower and wet bathroom, as well as built-in millwork for towels and robes, ensuring a luxurious and functional experience.



2. Spa Lounge

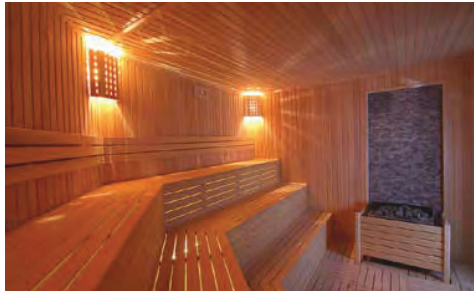

6. Sauna

West Tower Rooftop: Co-working

- 3
- 7

The co-working space features open seating, a kitchenette, a casual meeting area, and individual work pods. Designed with a hospitality-inspired aesthetic, the open seating area can transition seamlessly into a lounge or entertainment space during the evenings, offering flexibility and style. The design thoughtfully introduces private small work pods and meeting rooms, separate from the open entertaining space. These soundproof spaces are ideal for private calls, private work, media, and content creation.



3. Casual Meeting Area

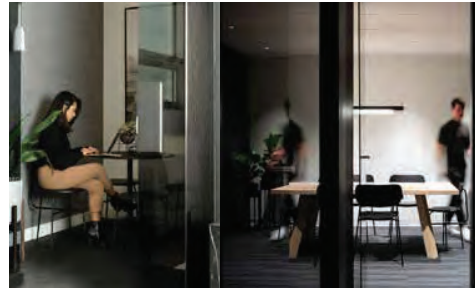

7. Private Work Pods / Meeting Room

Indoor Gym

- 4

The indoor gym, encompassing 1,499 square feet, is located on the ground floor with direct visibility from the main lobby. An additional 1,129-square-foot mezzanine level, accessible via internal stairs or the east tower elevator, complements the gym's design. In total, 2,628 square feet is dedicated to this fitness facility, which includes state-of-the-art equipment such as treadmills, lifting benches, step machines, exercise bikes, weight training stations, and mat-based workout areas.

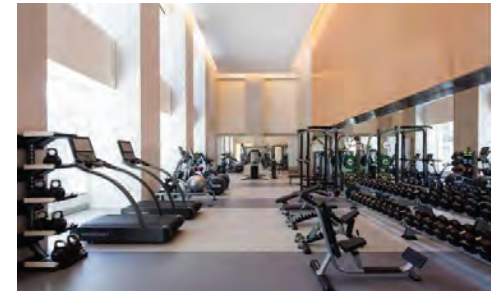

4. Indoor Gym



4. Indoor Gym

RESIDENTIAL INDOOR AMENITY



Main Lobby

8

The centrally located main lobby serves both the west and east towers, creating a shared, welcoming entryway. Designed with double-height ceilings (19'4"), it offers a grand and elegant first impression. The lobby features a seating lounge and a concierge desk, evoking the feel of a luxury hotel.



8. Main Entry Lobby

Mail Room & Parcel Room

9

The mail room incorporates a rear-loading mailbox system, with mailboxes integrated into a wall for dual access: the front faces the building lobby for resident use, while the back opens into the mail room for deliveries. The space is designed in accordance with Canada Post guidelines, accommodating 416 B-sized mailboxes and 42 D-sized mailboxes, ensuring sufficient capacity for all residents.

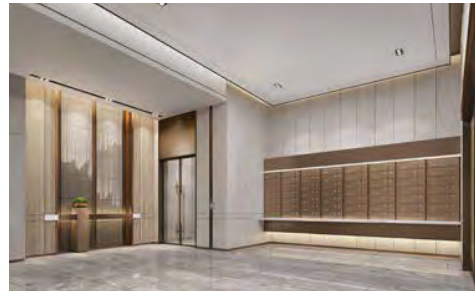

9. Mail Area

Pet Wash & Bicycle Repair

The development includes service-oriented indoor amenities, such as a bicycle maintenance room, a tool-lending library, and a snowboard/ski waxing station. A dedicated pet wash room is located on the lower bicycle mezzanine level, offering convenience and practicality for pet owners.



Bicycle Maintenance



Pet Wash

Leasing Office

10

A dedicated leasing office, including the building manager's workspace, is located on the mezzanine level. Accessible via stairs from the lobby or the east tower elevator, this office provides a functional and private workspace for management.

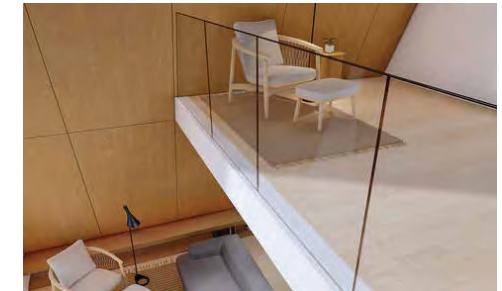

Leasing / Open Office



Leasing / Open Office



04 DESIGN RATIONALE

04.2 Residential Dwelling Units

RESIDENTIAL DWELLING UNITS

The proposed development provides a total of 416 residential units, including 62 studio units, 170 one-bedroom units, 142 two-bedroom units, and 42 three-bedroom units.

Forty percent of the units are family-friendly, meeting the city's requirements. All units will be adaptable and meet VBBL requirements.

Twenty percent of the total units will be Below Market Units, located on levels L2 to L5, L13 and L14. The Below Market rental housing will meet the affordability criteria and other requirements outlined in the Broadway Plan policies.

BALCONY IS ABOVE FOR WEATHER PROTECTION

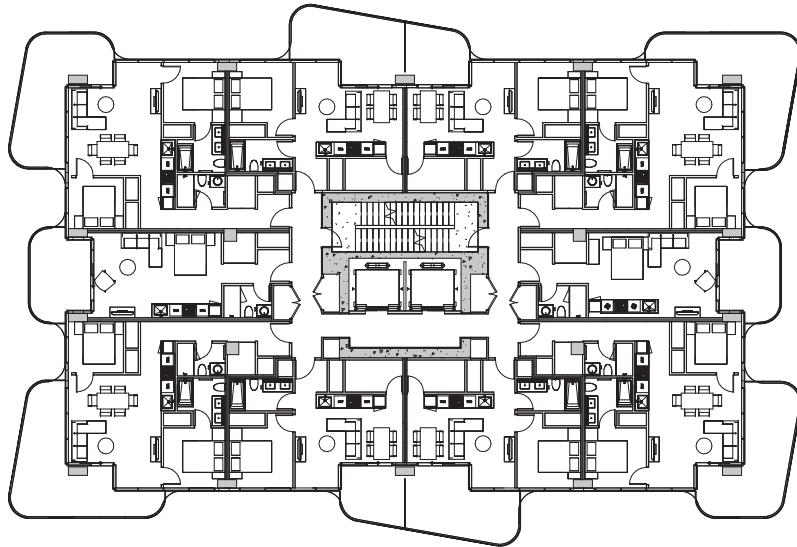

Floor Plan Lower Typical

WEST 6TH AVE SINGLE-LEVEL UNIT SUMMARY									
Unit Type	Unit	Area (sf.)	Area (sm.)	# of Units/Type	SubTotal /Type	Total # of Unit	Total GFA (sf.)	Average (sf.)	
Studio	S1	425	39.51	62	26,369	62	26,369	425	
	A1.1	530	49.28	82	43,498				
	A1.2	533	49.52	82	43,708				
One-Bedroom	A2.1	663	61.59	2	1,326	168	89,868	535	
	A2.2	668	62.05	2	1,336				
	B1	747	69.43	124	92,674	128	95,684	748	
Two-Bedroom	B2	753	69.91	4	3,010				
	C1.1	933	86.71	20	18,667	40	37,728	943	
Three-Bedroom	C1.2	953	88.54	20	19,061				

WEST 6TH AVE LOFT UNIT SUMMARY									
Unit Type	Unit	Area		# of Units/Type	SubTotal /Type	Total # of Unit	Total GFA	Average	
One-Bedroom	LA1	559	51.89	2	1,117	2	1,117	559	
	LB1.1	746	69.28	2	1,491				
	LB1.2	759	70.49	2	1,518				
	LB2	890	82.69	2	1,780				
Two-Bedroom	LB3.1	899	83.54	2	1,799	14	12,582	899	
	LB3.2	891	82.81	2	1,783				
	LB4.1	1035	96.12	2	2,069				
	LB4.2	1071	99.51	2	2,142				
Three-Bedroom	LC1	1012	93.97	2	2,023	2	2,023	1012	

WEST 6TH AVE RENTAL UNIT SUMMARY									
Unit Type	Unit	Area		# of Units/Type	SubTotal /Type	Total # of Unit	Total GFA	Average	
Studio						62	26,369	425	
One-Bedroom						170	90,985	535	
Two-Bedroom						142	108,266	762	
Three-Bedroom						42	39,751	946	
						416	265,371		

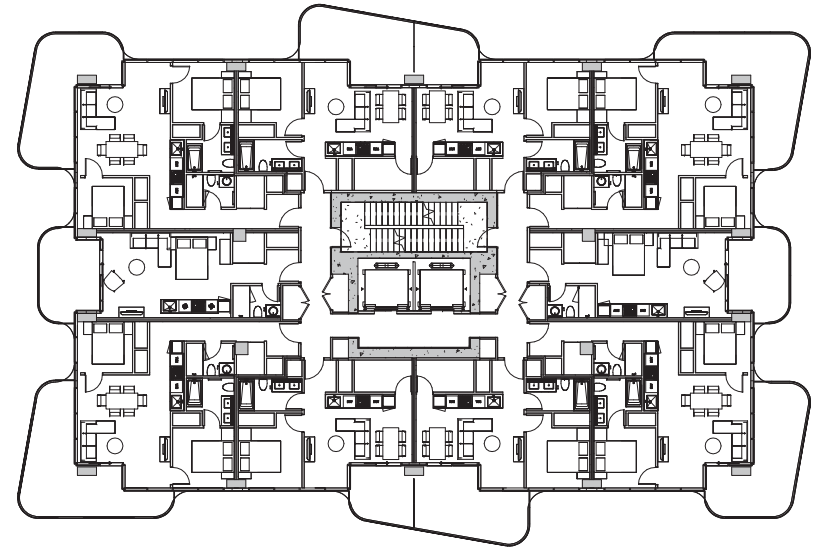

RESIDENTIAL DWELLING UNITS - LOFT

The proposed unit sizes comply with the minimum unit area guidelines. The floor-to-floor height is 10 feet for typical podium and tower levels, while penthouse units feature a 16-foot floor-to-floor height. Loft units have an 20-foot floor-to-floor height, with a clear headroom of 8 feet 4 inches on both the upper and lower levels where the mezzanine is located.

For the penthouse units, the increased floor-to-floor height partially accommodates mechanical ducting and piping for the hot tub on the amenity level above, which requires approximately 4 feet of clearance.

Interior Layout and Exterior Access

Bedrooms and living/dining areas are positioned directly adjacent to exterior walls and windows to maximize natural light and ventilation. An exception is found in eight bedrooms on the mezzanine level of the loft units, which are located above the kitchen and bathroom areas below.

Façade Depth Compliance

Units with exposure to a single exterior façade have a depth of 9.6 meters (31.5 feet), staying within the maximum allowable depth of 10.6 meters (35 feet) as per the design requirements.

WEST 6TH AVE LOFT UNIT SUMMARY								
Unit Type	Unit	Area		# of Units/Type	SubTotal/Type	Total # of Unit	Total GFA	Average
One-Bedroom	LA1	559	51.89	2	1,117	2	1,117	559
	LB1.1	746	69.28	2	1,491			
	LB1.2	759	70.49	2	1,518			
Two-Bedroom	LB2	890	82.69	2	1,780	14	12,582	899
	LB3.1	899	83.54	2	1,799			
	LB3.2	891	82.81	2	1,783			
	LB4.1	1035	96.12	2	2,069			
	LB4.2	1071	99.51	2	2,142			
Three-Bedroom	LC1	1012	93.97	2	2,023	2	2,023	1012

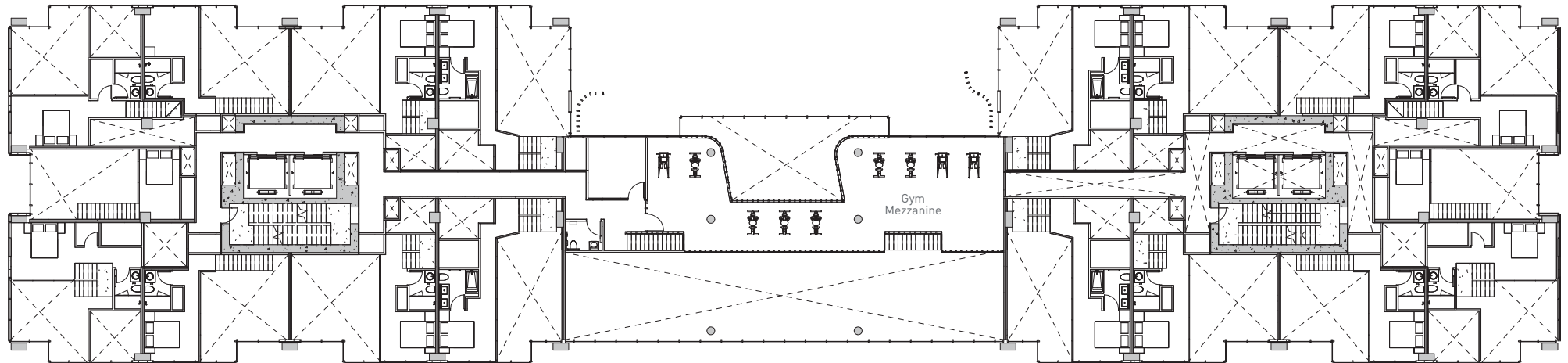
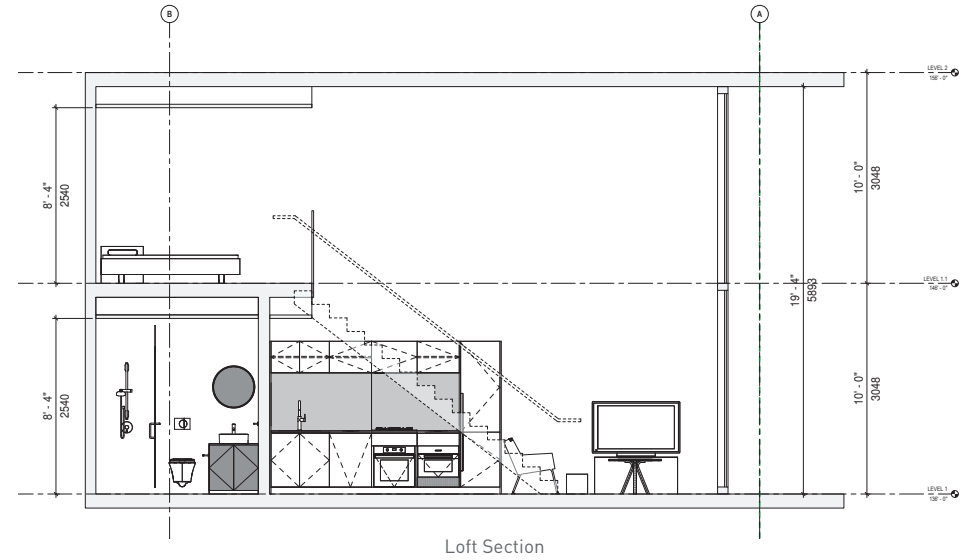

Floor Plan L1.1



04 DESIGN RATIONALE

04.3 Building Form

BUILDING FORM

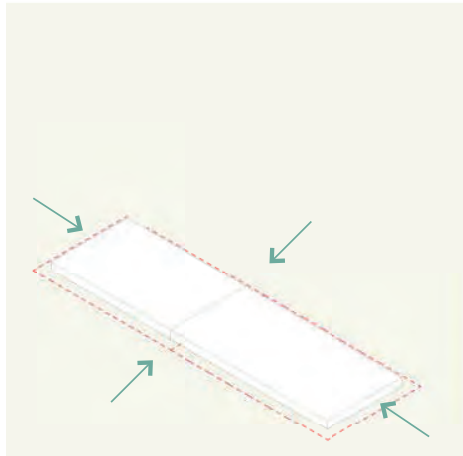
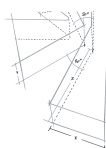

1 **Perimeter Setbacks**
Set full perimeter of site back by 12'.

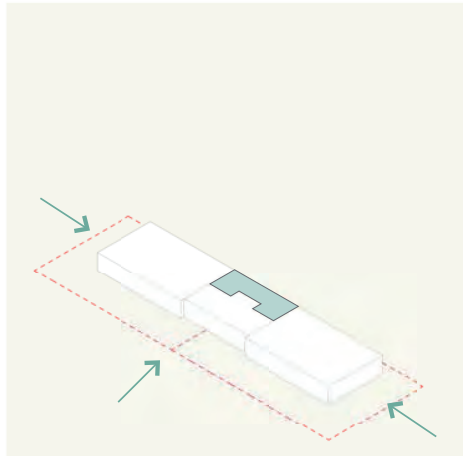

2 **Carve Grade Open Space**
Carve out central area at front for enhanced open space setback

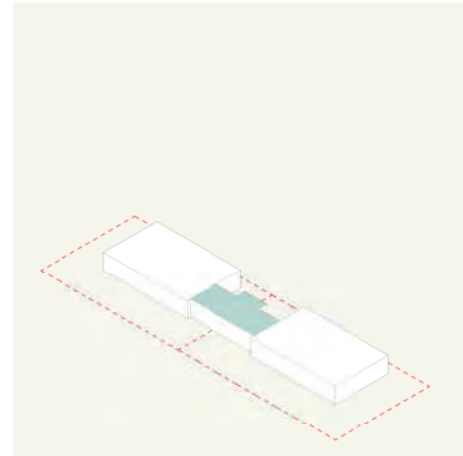

3 **Identify Tower Footprint**
Locate core to allow for efficient tower location and maximize outdoor amenity space

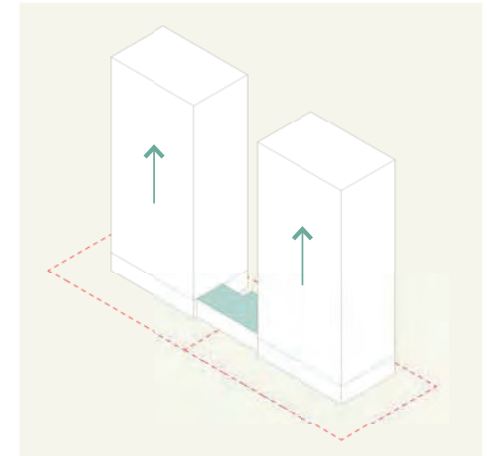

4 **Extrude Tower**
Setback tower and podium by 40' on all sides except the north which remains 12' and extrude tower by 21 storeys.

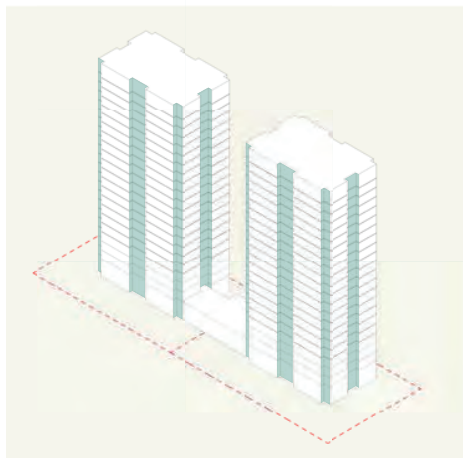

5 **Break down the Mass by Adding Recesses**
Carve massing to create deeper balconies.



6 **Extrude Amenity Areas**
Extrude and setback tower amenity to create large outdoor amenity areas.



7 **Extrude Elevator Room**
Extrude elevator rooms and provide space for mechanical equipment.

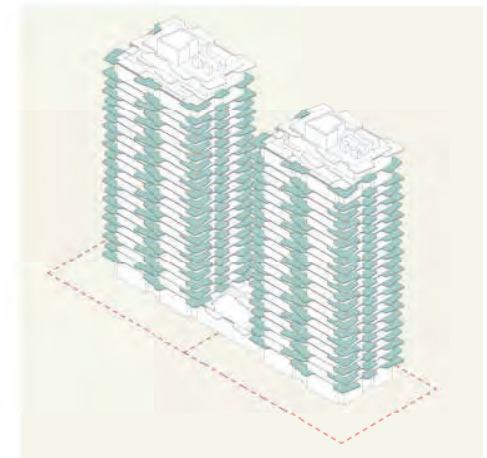

8 **Add Balconies**
Alternate the balconies' direction every other floor and provide a 10-degree angle to create movement and add to architectural expression.

BUILDING FORM



The building design strictly adheres to the city's setback requirements, including a 12-foot front yard setback, 40-foot west and east side yard setbacks, a 40-foot rear yard setback, and a minimum 80-foot tower separation. Despite these constraints, the development successfully achieves the 6.5 FAR density target, complying with applicable exemptions for indoor amenities, in-suite storage areas, and rooftop mechanical and elevator spaces.

The proposed design reduces the perceived mass of the building by incorporating recessed balconies at the corners and the center of the tower. This approach effectively breaks down the 106-foot-long façade into two 36-foot-long primary surfaces, interspersed with three recessed sections. The resulting narrower and more varied surfaces create a more streamlined and visually appealing façade, contributing to a refined architectural expression.

3D VIEW - NORTHEAST



3D VIEW - SOUTHEAST





04 DESIGN RATIONALE

04.4 Architectural Expression

BALCONY SHIFTING

Constrained by setback and tower separation requirements, the proposed development introduces a 10-degree angle to the balconies, alternating their orientation on every other floor. This design creates a sense of dynamic movement, further enhancing the building's architectural expression.

The balconies are thoughtfully designed to offer generous private outdoor spaces for each unit. Their depths exceed the minimum 6-foot requirement, ranging from 6 feet at the shallower end to a maximum of 9 feet 6 inches at the deeper end. These spacious balconies enhance livability, functionality, and access to outdoor areas, significantly improving the residential experience.

Additionally, the balconies provide practical benefits by creating overhangs for the window wall system. These overhangs offer weather protection for the building envelope and help mitigate heat gain and glare during summer months, contributing to the building's energy efficiency and comfort.

Balcony - West



Balcony - East



BALCONY SHIFTING - DIMENSIONS

The average balcony depth is 6 feet 4 inches (1.93 meters), with depths ranging from 6 feet (1.83 meters) at the shallowest point to 9 feet 6 inches (2.89 meters) at the deepest.

The average balcony size is 13.4 square meters (145.92 square feet), varying by unit type:

- Studio units: Balconies are 120.91 square feet.
- One-bedroom units: Balconies range from 87.55 to 168.67 square feet.
- Two-bedroom units: Balconies range from 208.31 to 241.43 square feet.
- Three-bedroom units: Balconies range from 60.46 to 241.43 square feet.

These thoughtfully designed balconies provide residents with ample private outdoor space, enhancing livability and catering to a variety of unit types and preferences.

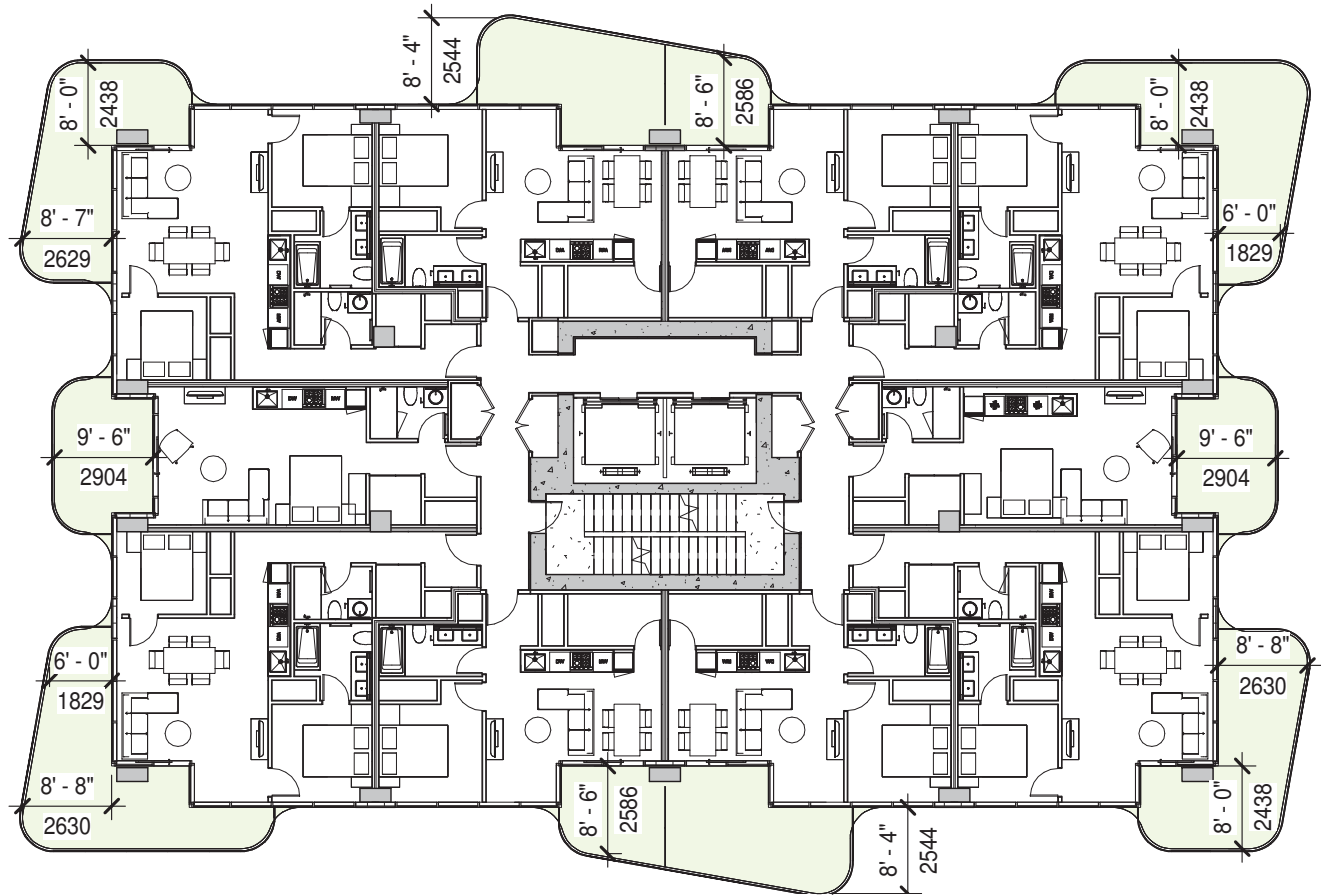

ARCHITECTURAL EXPRESSION



ARCHITECTURAL EXPRESSION

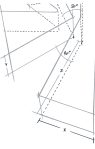

ARCHITECTURAL EXPRESSION



ARCHITECTURAL EXPRESSION





05 PROJECT STATISTICS / DATA 05.1 Site Area

Proposed Uses

Unit Breakdown

Floor Area

Floor Space Ratio (FSR)

Floor Area included in FSR

Floor Area Exclusions

PROJECT STATISTICS - FAR & UNIT MIX

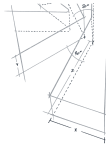

FAR SUMMARY

PROVIDED FAR AREA		
RESIDENTIAL	27,169 s.m.	292,449 s.ft.
TOTAL	27,169 s.m.	292,449 s.ft.
PROVIDED FAR EXCLUSION AREA		
INDOOR AMENITY (RECREATIONAL)	898 s.m.	9,668 s.ft.
SERVICE	460 s.m.	4,949 s.ft.
STORAGE	1517 s.m.	16,330 s.ft.
TOTAL	2875 s.m.	30,947 s.ft.
FAR CALCULATION		
FAR AREA	27169 s.m.	292,449 s.ft.
SITE AREA	4180 s.m.	44,992 s.ft.
FAR	6.50	
OUTDOOR SPACE		
BALCONY & PATIO (PRIVATE)	7,119 s.m.	76,632 s.ft.
OUTDOOR AMENITY (COMMON)	1,593 s.m.	17,145 s.ft.
TOTAL	8,712 s.m.	93,777 s.ft.

2280 - 2244 WEST 6TH UNIT MIX

RESIDENTIAL UNIT MIX - WEST 2280 TOWER							
AREA RANGE	425sf	530-668f	746-1071sf	933-1011sf	# UNITS	MARKET TYPE	
UNIT TYPE	STUDIO	1 BR	2 BR	3 BR			
25				ROOF			
24				MECH			
23				INDOOR / OUTDOOR AMENITY			
22	1	4	2	2	9	MARKET	
21	1	4	2	2	9		
20	1	4	2	2	9		
19	1	4	2	2	9		
18	1	4	2	2	9		
17	1	4	2	2	9		
16	1	4	2	2	9		
15	1	4	2	2	9		
14	1	4	2	2	9		2 B/M
13	1	4	2	2	9		2 B/M
12	2	4	4	/	10	MARKET	
11	2	4	4	/	10		
10	2	4	4	/	10		
9	2	4	4	/	10		
8	2	4	4	/	10		
7	2	4	4	/	10		
6	2	4	4	/	10		
5	2	4	4	/	10		9 B/M
4	2	4	4	/	10		10 B/M
3	2	4	4	/	10		10 B/M
2	1	4	4	/	9	9 B/M	
1	/	1	7	1	9	MARKET	
# UNITS	31	85	71	21	208		

WEST TOWER UNITS	BELOW MARKET	MARKET
STUDIO	31	7 17%
1 BR	85	16 38%
2 BR	71	15 36%
3 BR	21	4 10%
TOTAL	208	42 100%

TOTAL BELOW MARKET UNIT MIX RATIO			
	TARGET	ACTUAL	
		COUNT	MIX
STUDIO		14	17%
1 BR		32	38%
2 BR		30	36%
3 BR		8	10%
TOTAL	84	84	100%

RESIDENTIAL UNIT MIX - EAST 2244 TOWER

RESIDENTIAL UNIT MIX - EAST 2244 TOWER							
AREA RANGE	425sf	530-668f	746-1071sf	933-1011sf	# UNITS	MARKET TYPE	
UNIT TYPE	STUDIO	1 BR	2 BR	3 BR			
25				ROOF			
24				MECH			
23				INDOOR / OUTDOOR AMENITY			
22	1	4	2	2	9	MARKET	
21	1	4	2	2	9		
20	1	4	2	2	9		
19	1	4	2	2	9		
18	1	4	2	2	9		
17	1	4	2	2	9		
16	1	4	2	2	9		
15	1	4	2	2	9		
14	1	4	2	2	9		2 B/M
13	1	4	2	2	9		2 B/M
12	2	4	4	/	10	MARKET	
11	2	4	4	/	10		
10	2	4	4	/	10		
9	2	4	4	/	10		
8	2	4	4	/	10		
7	2	4	4	/	10		
6	2	4	4	/	10		
5	2	4	4	/	10		9 B/M
4	2	4	4	/	10		10 B/M
3	2	4	4	/	10		10 B/M
2	1	4	4	/	9	9 B/M	
1	/	1	7	1	9	MARKET	
# UNITS	31	85	71	21	208		

EAST TOWER UNITS	BELOW MARKET	MARKET
STUDIO	31	7 17%
1 BR	85	16 38%
2 BR	71	15 36%
3 BR	21	4 10%
TOTAL	208	42 100%

TOTAL UNIT MIX RATIO			
	AVERAGE SF	ACTUAL	
		COUNT	MIX
STUDIO	425	62	15%
1 BR	535	170	41%
2 BR	762	142	34%
3 BR	946	42	10%
TOTAL		416	100%

PROJECT STATISTICS / DATA



BYLAW PARKING REQUIREMENTS

VISITOR	416		0.050		20.8	SEC04 4.1.16	0.05 spaces per unit
RESIDENTIAL TOTAL							
ACCESSIBLE	7				1	SEC04 4.8.3(a)	1 space for the first 7 residential units and an additional 0.034 for each additional unit.
	409		0.034		13.9		
					15		The accessible parking spaces are included in the total 148 spaces requirements.
PARKING PROVIDED							
VISITOR PARKING		RV1	RV2	RV3	SV	AV	PARKING SPACE REQUIREMENTS
P0	21		13		7	1	2500W X 5500L X 2000H
SUB TOTAL	21	0	13		7	1	2700W X 5500L X 2000H
RESIDENTIAL PARKING		RR1	RR2	RR3	SR	AR	PARKING SPACE REQUIREMENTS
P1	44	0	27		11	6	2900W X 5500L X 2000H
P2	76	0	50	0	18	8	2300W X 4600L X 2000H
SUB TOTAL	120	0	77	0	29	14	(2500W+1500 PATH) X 5500L X 2300H
TOTAL	141						
					TOTAL SMALL CAR		
							26%
LOADING REQUIREMENTS							
LAND USE	UNIT NUMBER	CLASS A	CLASS B	CLASS C	BYLAW REFERENCE		
SECURED RENTAL	416	2	2		SEC 05 5.2.1	At least 1 class B loading space for 100-299 units, a minimum of one additional space for 300 to 499 dwelling units	
					SEC 05 5.2.1	At least 1 class A loading space for 50-299 units and at least one additional space for any portion of each additional 200 dwelling units	
PASSENGER LOADING REQUIREMENTS							
LAND USE	UNIT NUMBER	CLASS A	CLASS B	CLASS C	BYLAW REFERENCE		
SECURED RENTAL	416	3			SEC 07 7.2.1	At least 1 class A loading space for 50-125 dwelling units plus one space for every additional 150 dwelling units	
LOADING PROVIDED							
LEVELS		CLASS A	CLASS B	CLASS A PASSENGER	LOADING SPACE REQUIREMENTS		TAG
P0		2		3	(2500W+1500 PATH) X 5500L X 2300H		LA, PA
LEVEL 1			2		10200L X 3400W X 3800H		LB

BYLAW BICYCLE REQUIREMENTS

LAND USE	UNIT NUMBER	RATIO	BYLAW REQUIRED	BYLAW SECTION	BYLAW REFERENCE	TDM ADDITION	SPACES
SECURED RENTAL	232	1.5	CLASS A	348	SEC06 6.2.1.2 A minimum of 1.5 spaces for every unit under 65m ² A minimum of 2.5 spaces for every unit over 65m ² & under 105m ² A minimum of 3 spaces for every unit over 105m ²	30%	104
	184	2.5	CLASS A	460	SEC06 6.2.1.2 A minimum of 1.5 spaces for every unit under 65m ² A minimum of 2.5 spaces for every unit over 65m ² & under 105m ² A minimum of 3 spaces for every unit over 105m ²	30%	138
	416		CLASS B	21.8	SEC06 6.2.1.2 A minimum of 2 spaces for any development containing at least 20 dwelling units, and one additional space for every additional 20 dwelling units		
				830		AFTER ADDITION	1073 2.58
CLASS A							
	1051	MINIMUM	105	SEC06 6.6.3.9	900W X 2400L X 1900H	O OVERSIZED	10% of the total number Class A spaces to be oversized spaces TDM Plan B
		MAXIMUM	315	SEC06 6.6.3.13	600W X 1000L X 1900H	V VERTICAL	No more than 30% of the required Class A bicycle spaces may be vertical SEC06 6.3.13
				SEC06 6.6.3.13	600W X 1800L X 1900H	S STACKED	no more than 60% of the required Class A bicycle spaces may be vertical and stacked SEC06 6.3.13
BICYCLES PROVIDED							
CLASS B					BICYCLE SPACE REQUIREMENTS	BYLAW REFERENCE	BYLAW SECTION
P0.1	22				600W X 1800L X 1900H	CB CLASS B	All required Class B bicycle spaces shall be provided in racks which provide a minimum width of 0.6 m for each bicycle. SEC06 6.4.2
SUB TOTAL	22						
CLASS A		OVERSIZED	VERTICAL	STACKED	HORIZONTAL		
P0.1	1051	105	305		641	O OVERSIZED	a minimum of 5% of the spaces must be oversized spaces SEC06 6.9.3
LEVEL 1	0	0				V VERTICAL	No more than 30% of the required Class A bicycle spaces may be vertical SEC06 6.3.13
LEVEL 2	0	0				S STACKED	no more than 60% of the required Class A bicycle spaces may be vertical and stacked SEC06 6.3.13
SUB TOTAL	1051	105	305		641	H HORIZONTAL	
TOTAL	1073						



06 ARCHITECTURAL DRAWINGS

06.1 Context Map

CONTEXT MAP

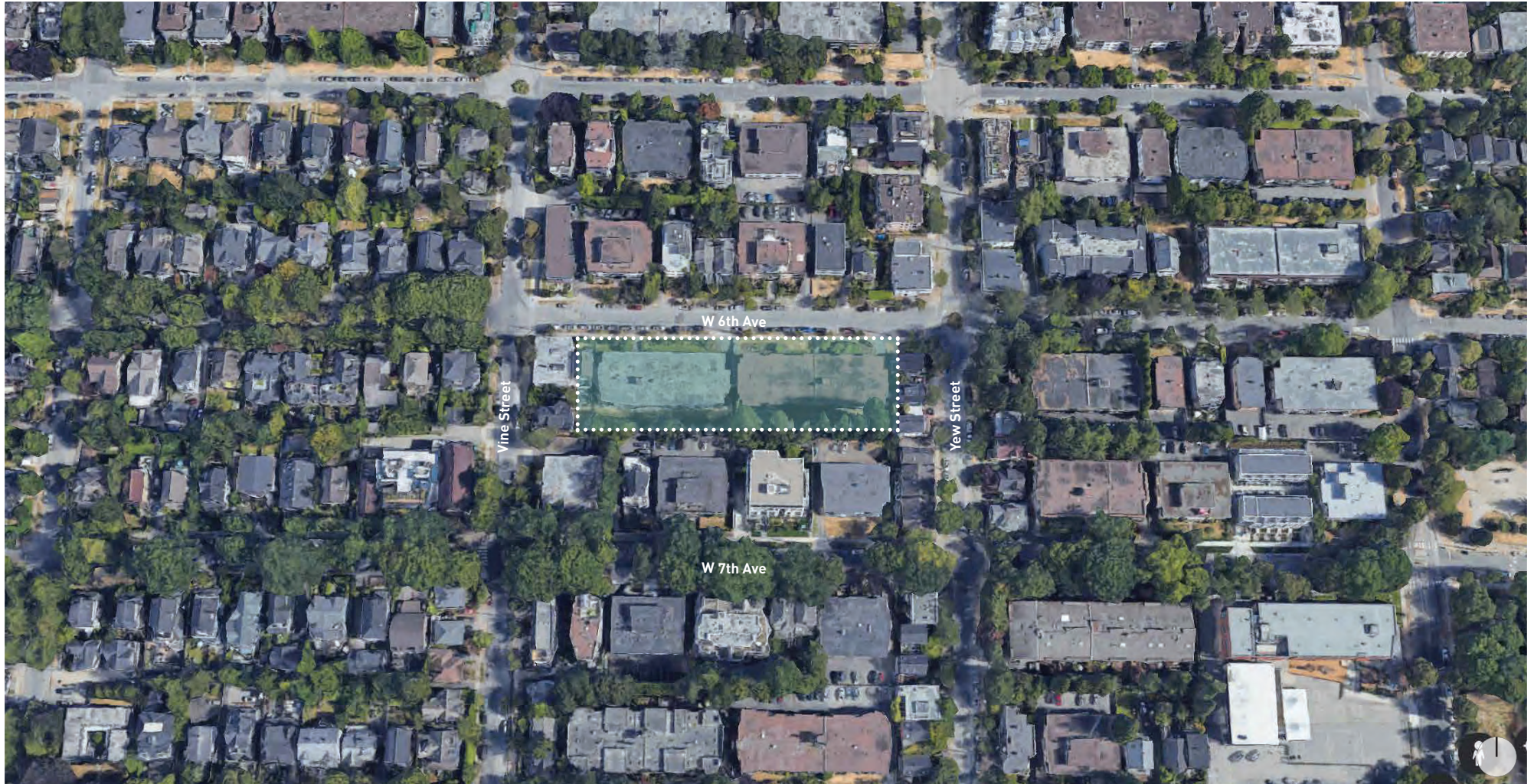

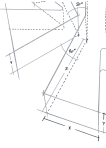

06 ARCHITECTURAL DRAWINGS

06.2 Site Plan

SITE PLAN

Scale 1:400

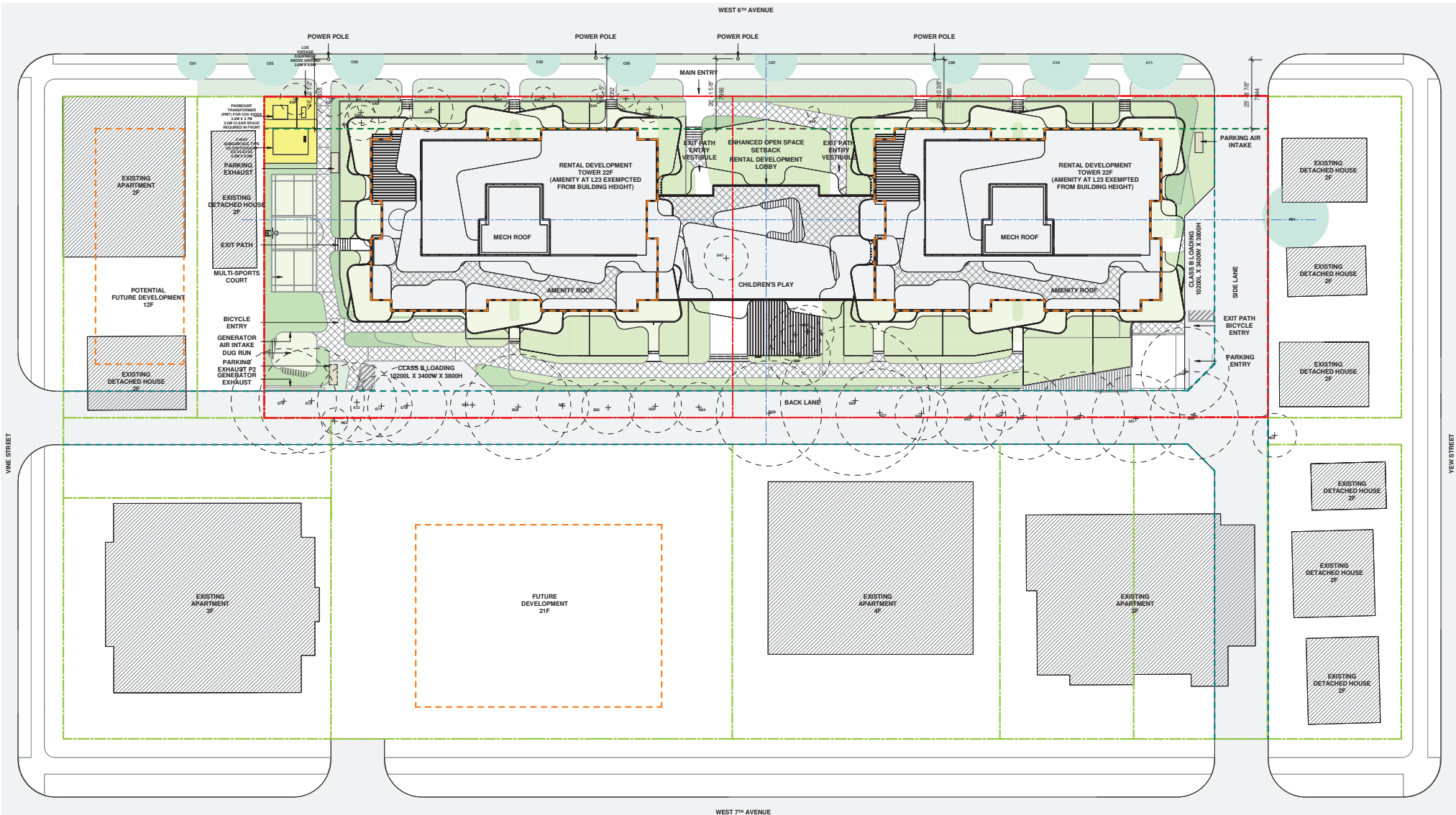

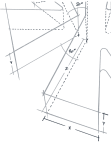

06 ARCHITECTURAL DRAWINGS

06.3 Floor Plans

FLOOR PLAN P2

Scale 1:300

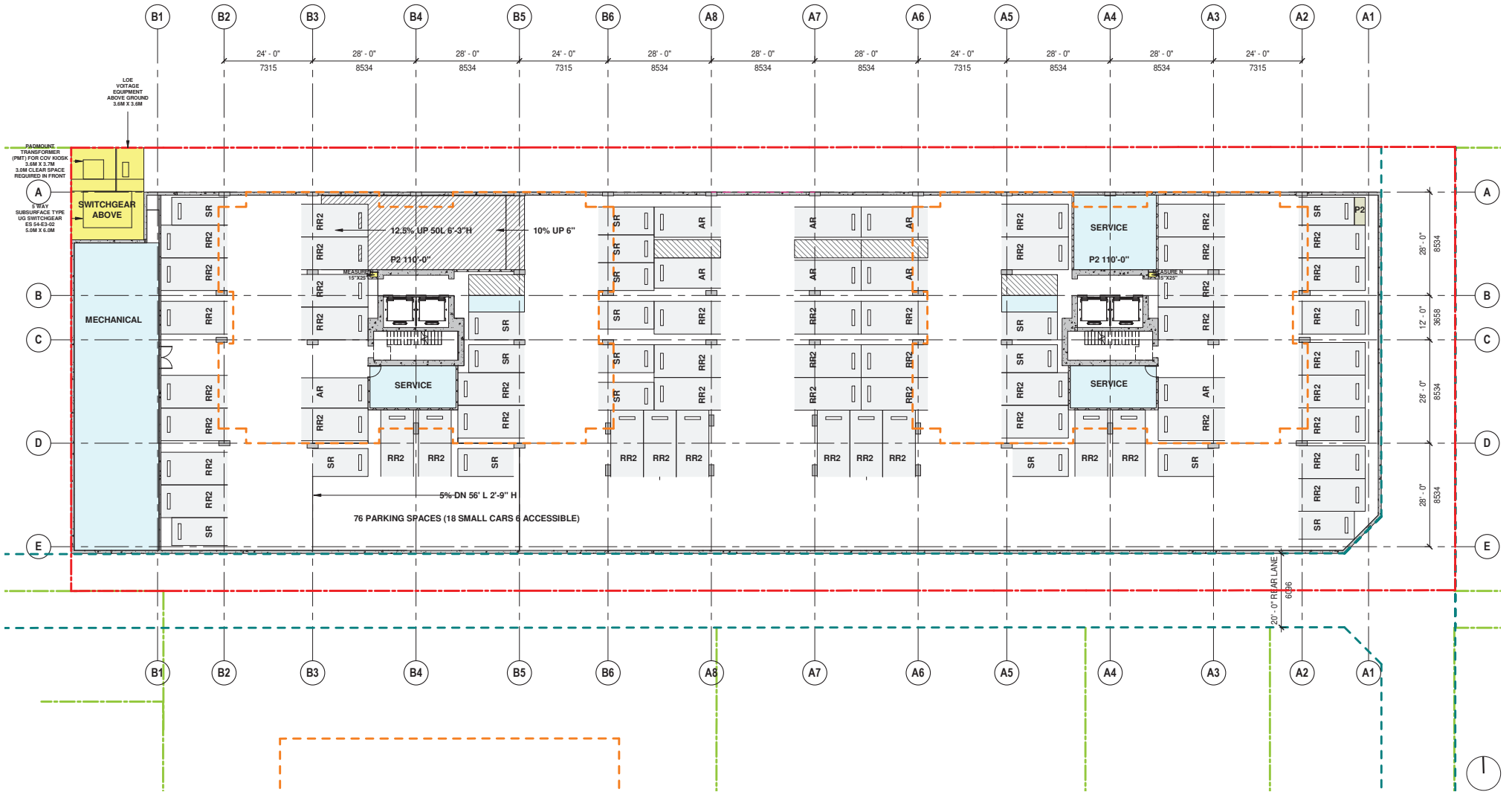

FLOOR PLAN P1

Scale 1:300

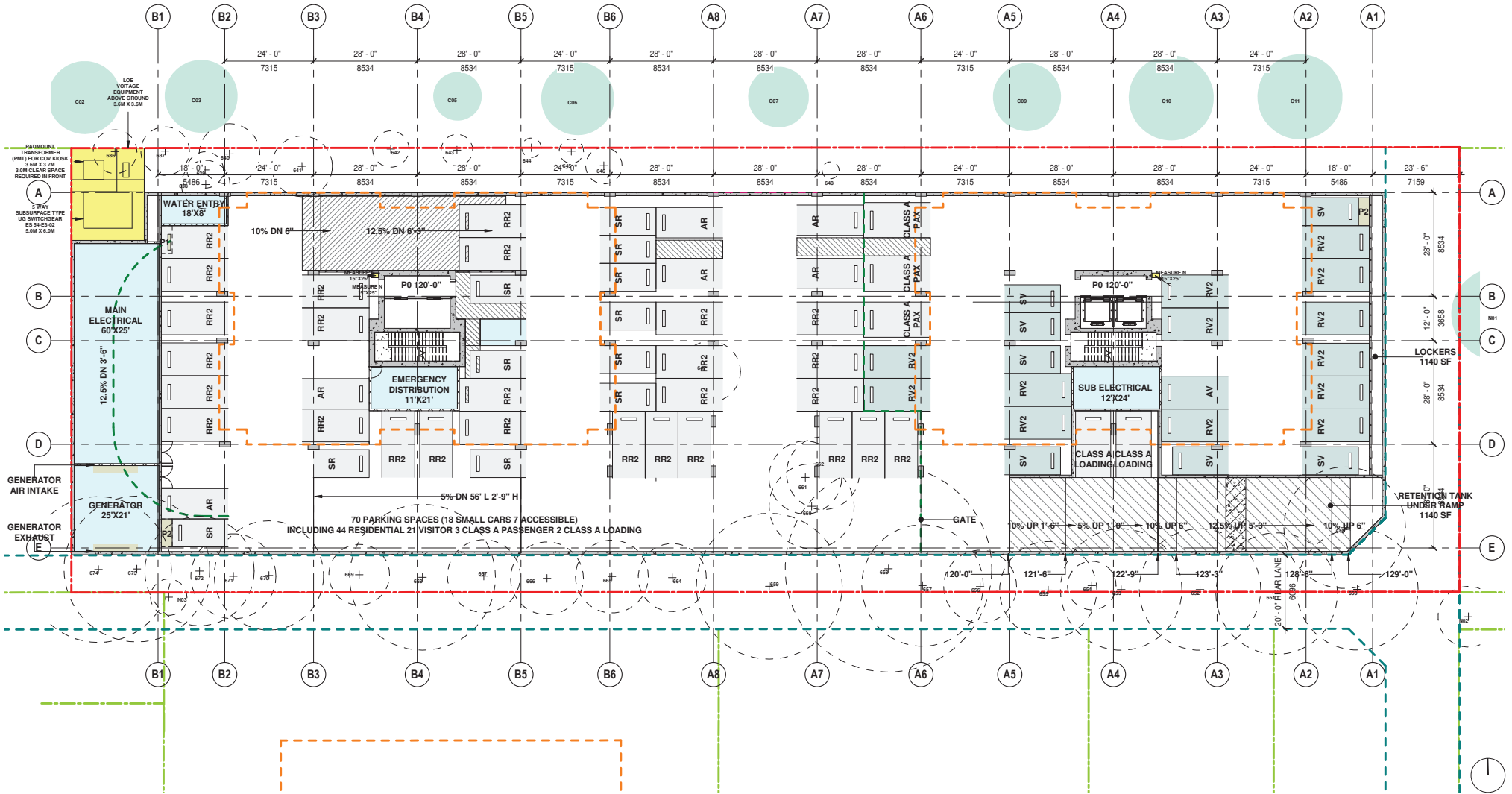

FLOOR PLAN P1.1

Scale 1:300

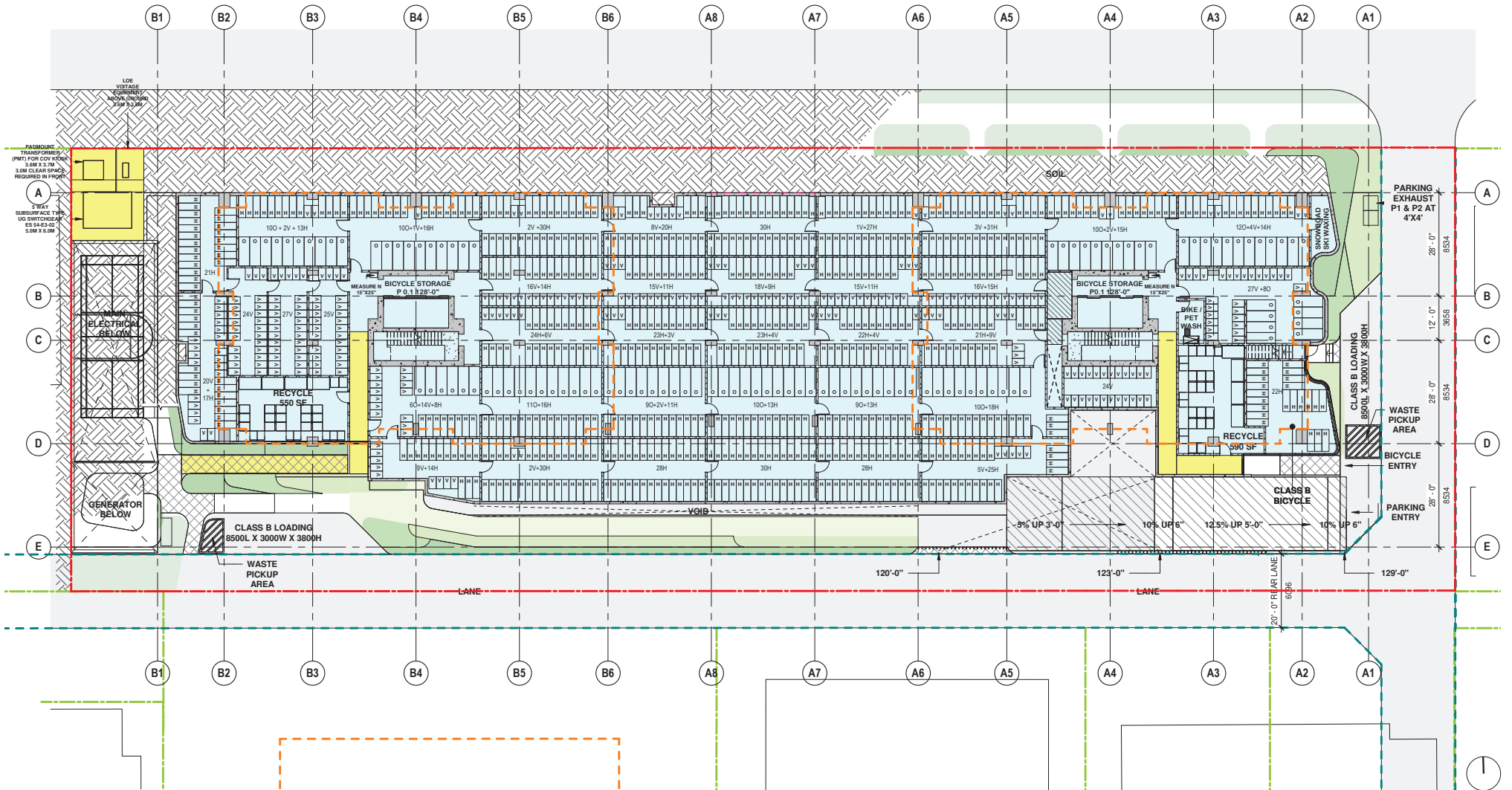

FLOOR PLAN L1

Scale 1:300

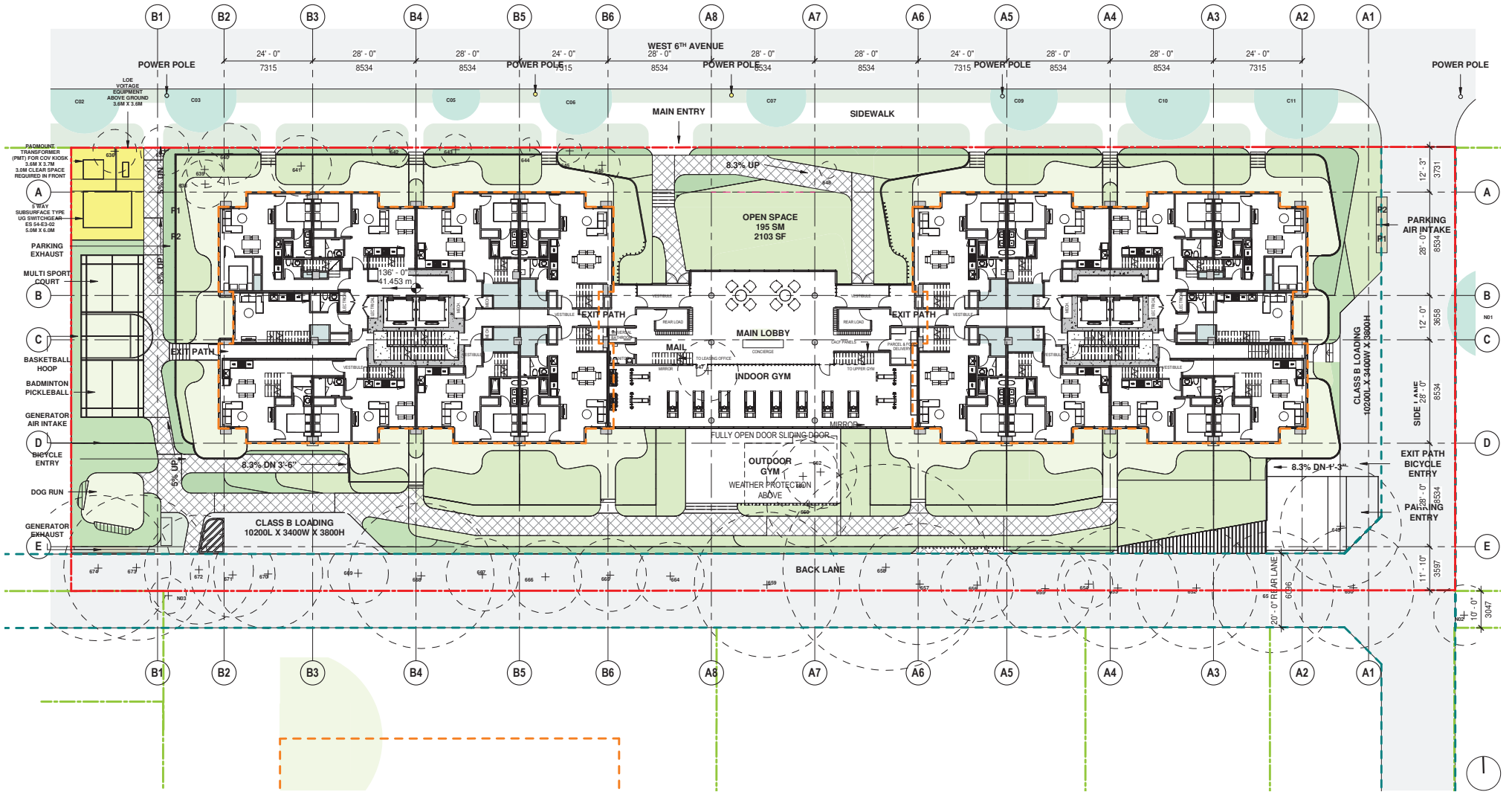

LEGEND
 IN - SUITE STORAGE - TO BE EXEMPTED

FLOOR PLAN L1.1

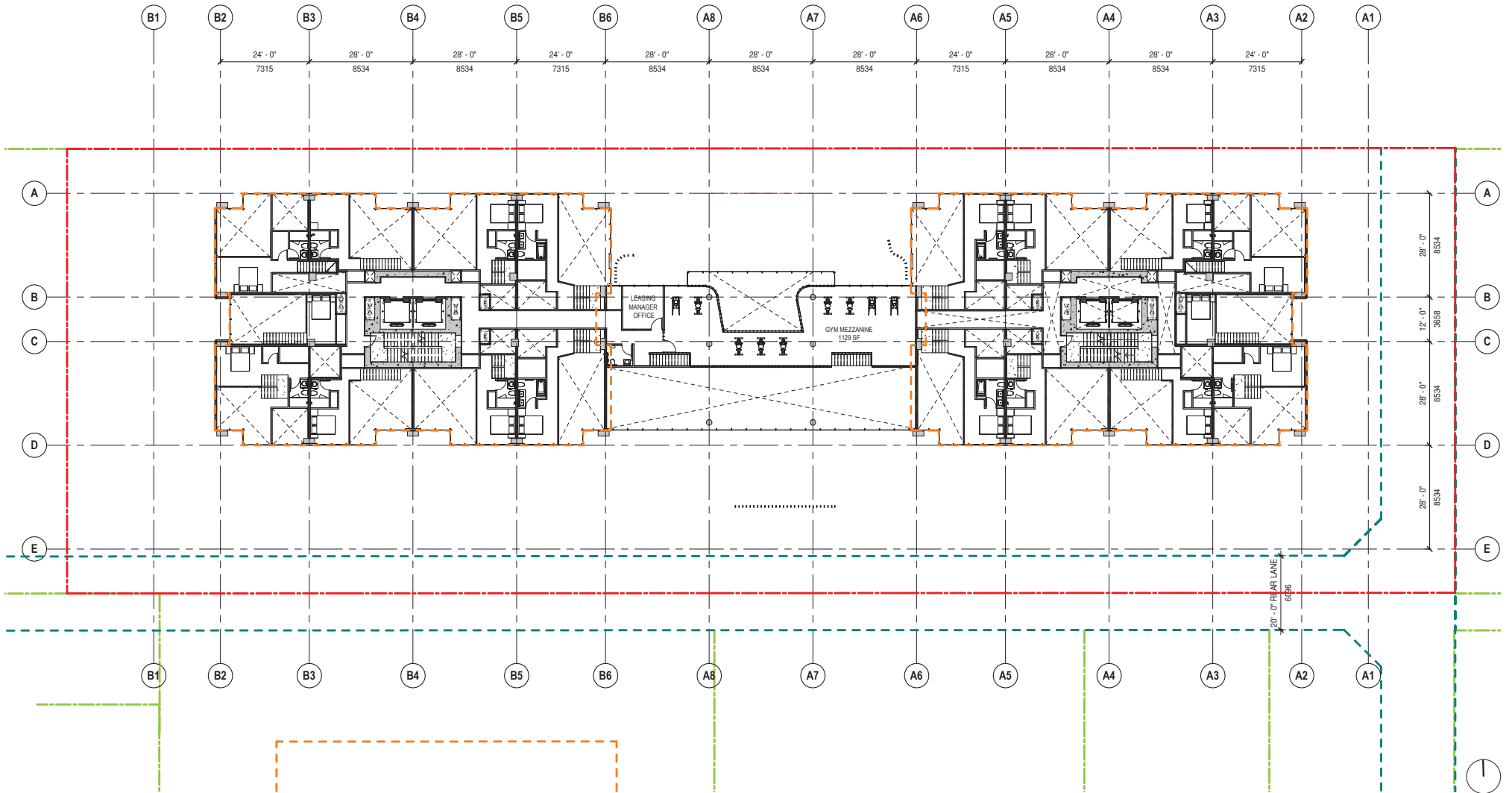

FLOOR PLAN L2

Scale 1:300

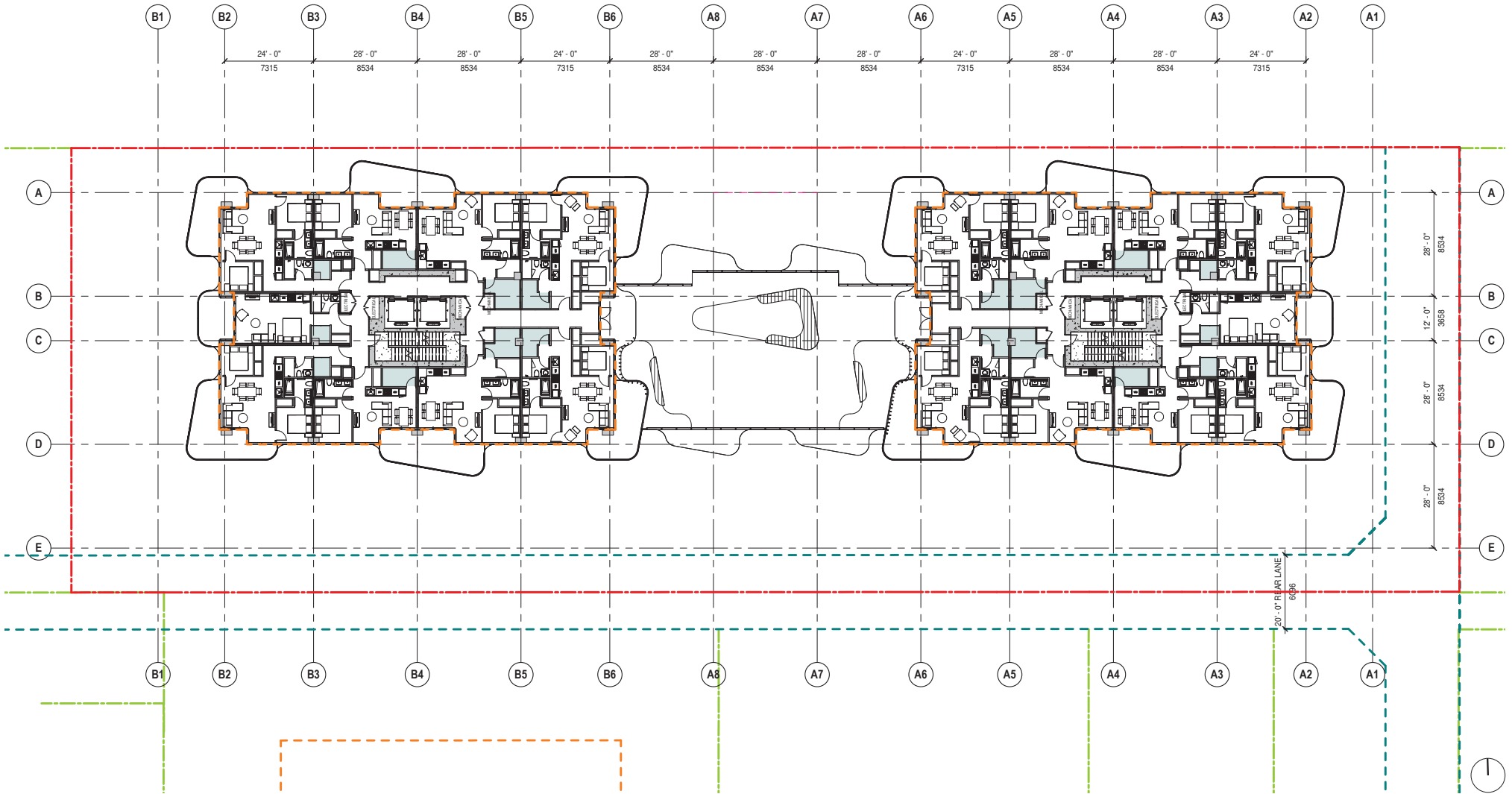
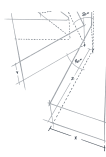

LEGEND
 IN - SUITE STORAGE - TO BE EXEMPTED
 BELOW MARKET UNITS

FLOOR PLAN L3-12

Scale 1:300

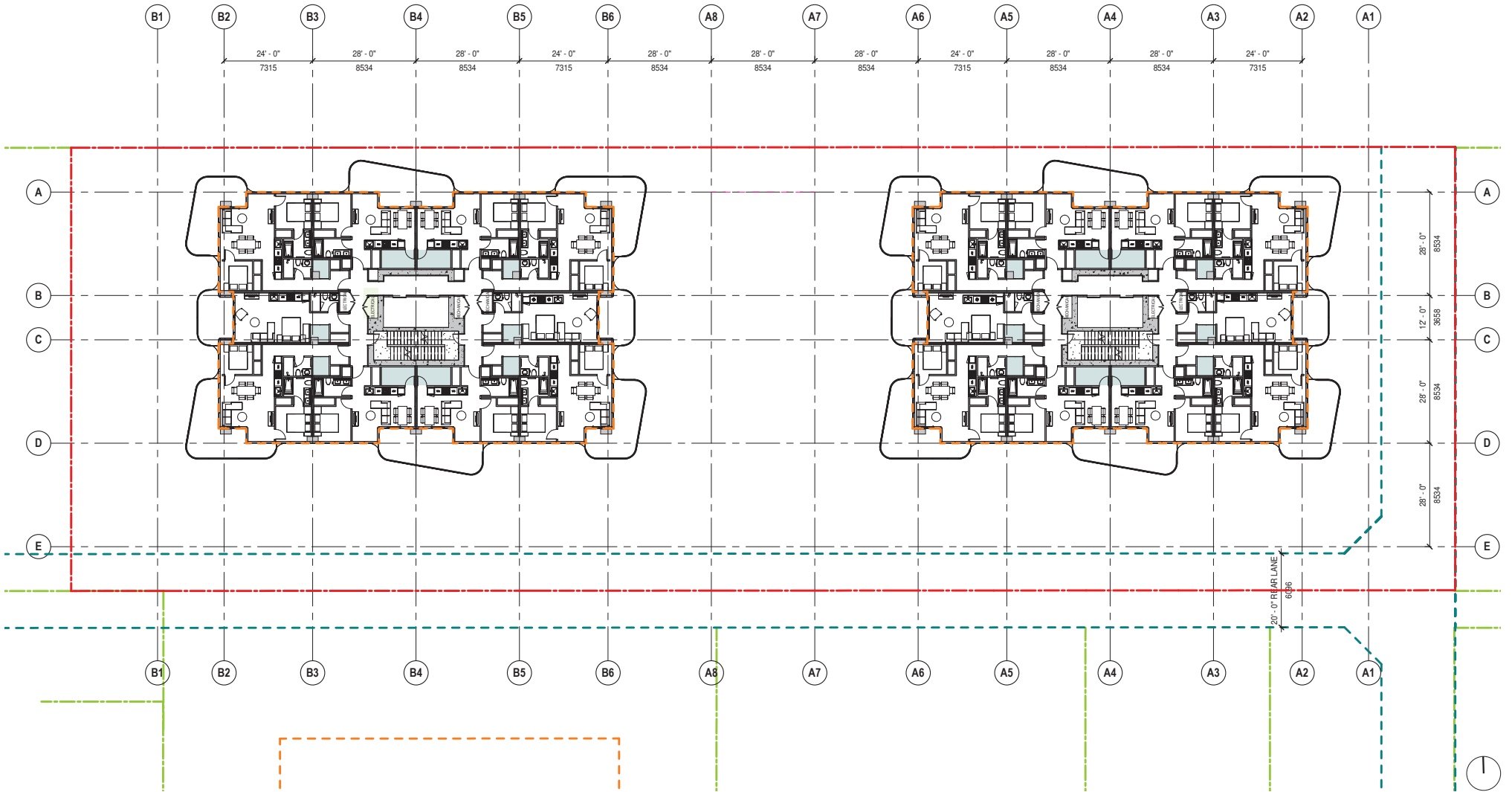

LEGEND
 IN - SUITE STORAGE - TO BE EXEMPTED

FLOOR PLAN L3-22

Scale 1:300

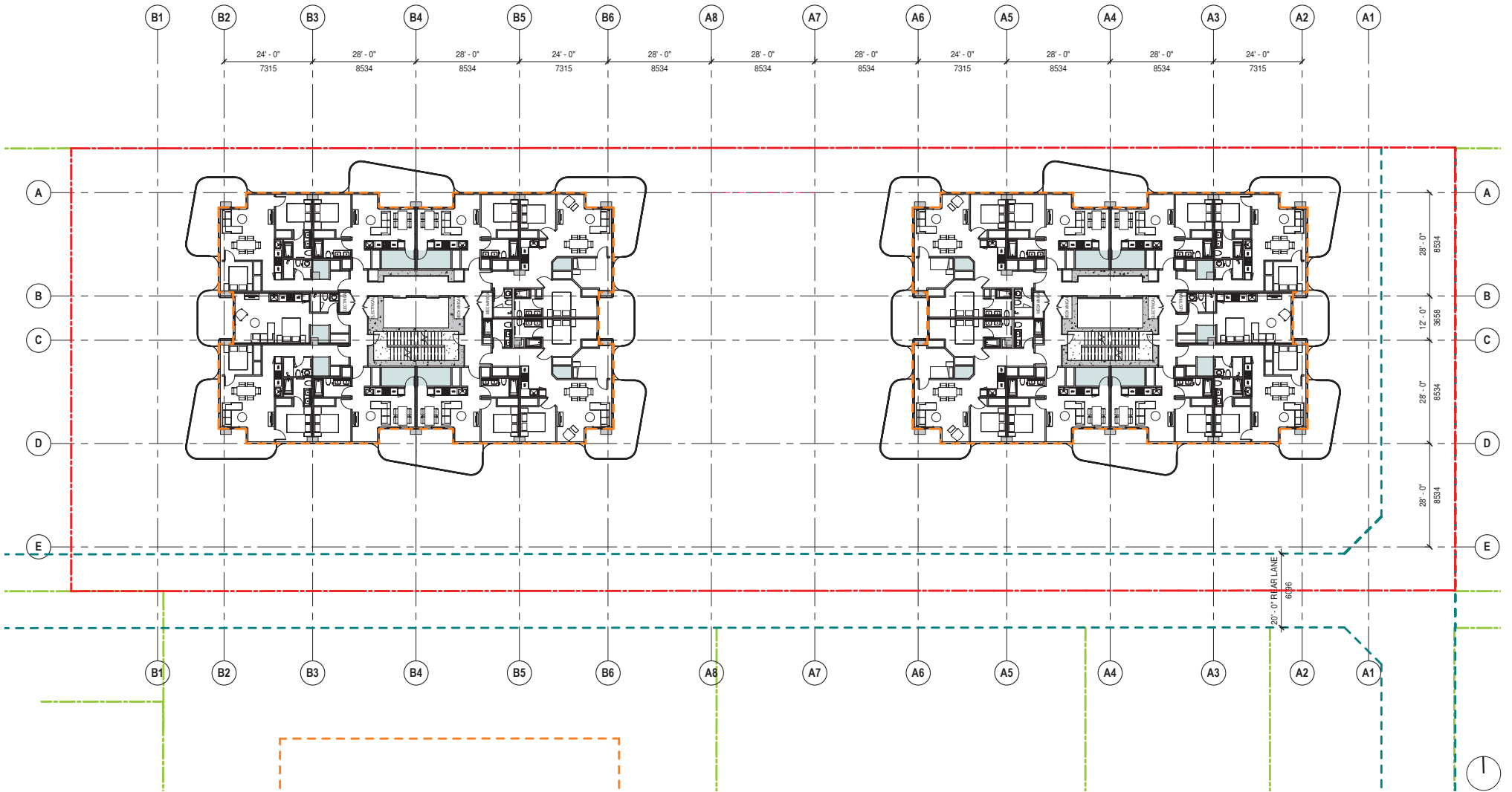
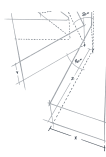

LEGEND
 IN - SUITE STORAGE - TO BE EXEMPTED
 COMMON STORAGE - TO BE EXEMPTED

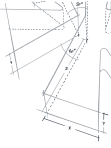

06 ARCHITECTURAL DRAWINGS

06.4 Landscape Plans

Issues	No.	Description	Date
	1	Issued for 100% SD	2024/10/24
	2	Issued for Review	2025/06/06



COPYRIGHT RESERVED
This drawing is and shall remain the property of Perry and Associates Inc. and Perry and Associates Inc. shall retain the copyright therein. This document shall not be reproduced or used for purposes or alterations to the project or for the purpose of any other project without the prior written consent of Perry and Associates Inc.
Client:

Project Title:
2244 - 2280 W 6th Avenue

Drawing Title:
Landscape Concept Plan L1

Project North:	Drawn By:	CS
	Checked By:	JP
Scale:	Job No.:	24-043
1:150	Sheet No.:	

L1.0

10/10/2024 10:06:06

Issues	No.	Description	Date
	1	Issued for 100% SD	2024/10/04
	2	Issued for Review	2025/06/06

COPYRIGHT RESERVED
This drawing is and shall remain the property of Perry and Associates Inc. and Perry and Associates Inc. shall retain the copyright therein. This document shall not be reproduced or used for purposes or alterations to the project or for the purpose of any other project without the prior written consent of Perry and Associates Inc.

Client: _____

Project Title:
2244 - 2280 W 6th Avenue

Drawing Title:
Landscape Concept Plan L2

Project North:  Drawn By: **CS**
Checked By: **JP**
Scale: **1:50** Job No.: **24-043**
Sheet No.: _____

L1.1

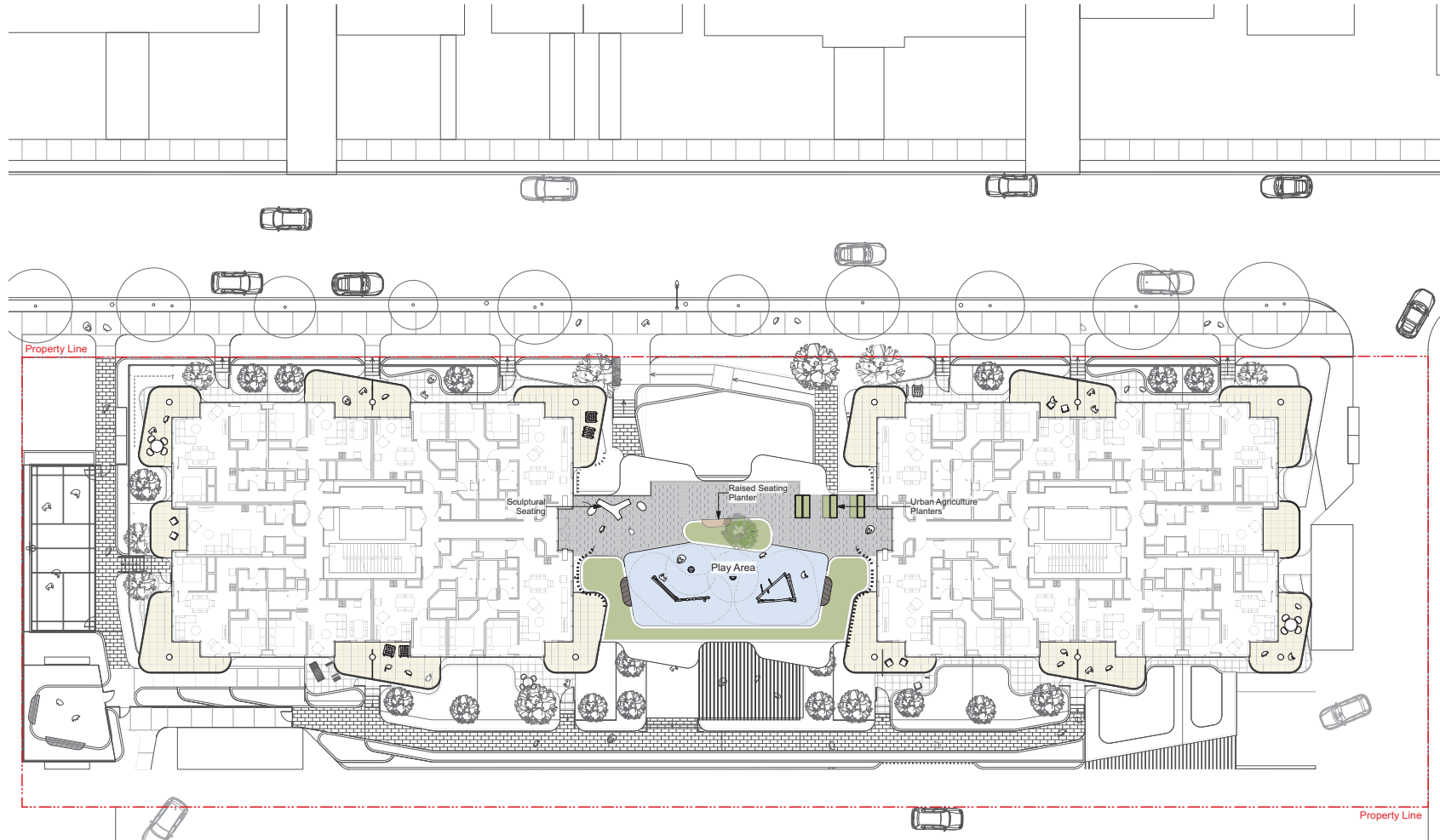

Issues	No.	Description	Date
	1	Issued for 100% SD	2024/10/24
	2	Issued for Review	2025/06/06

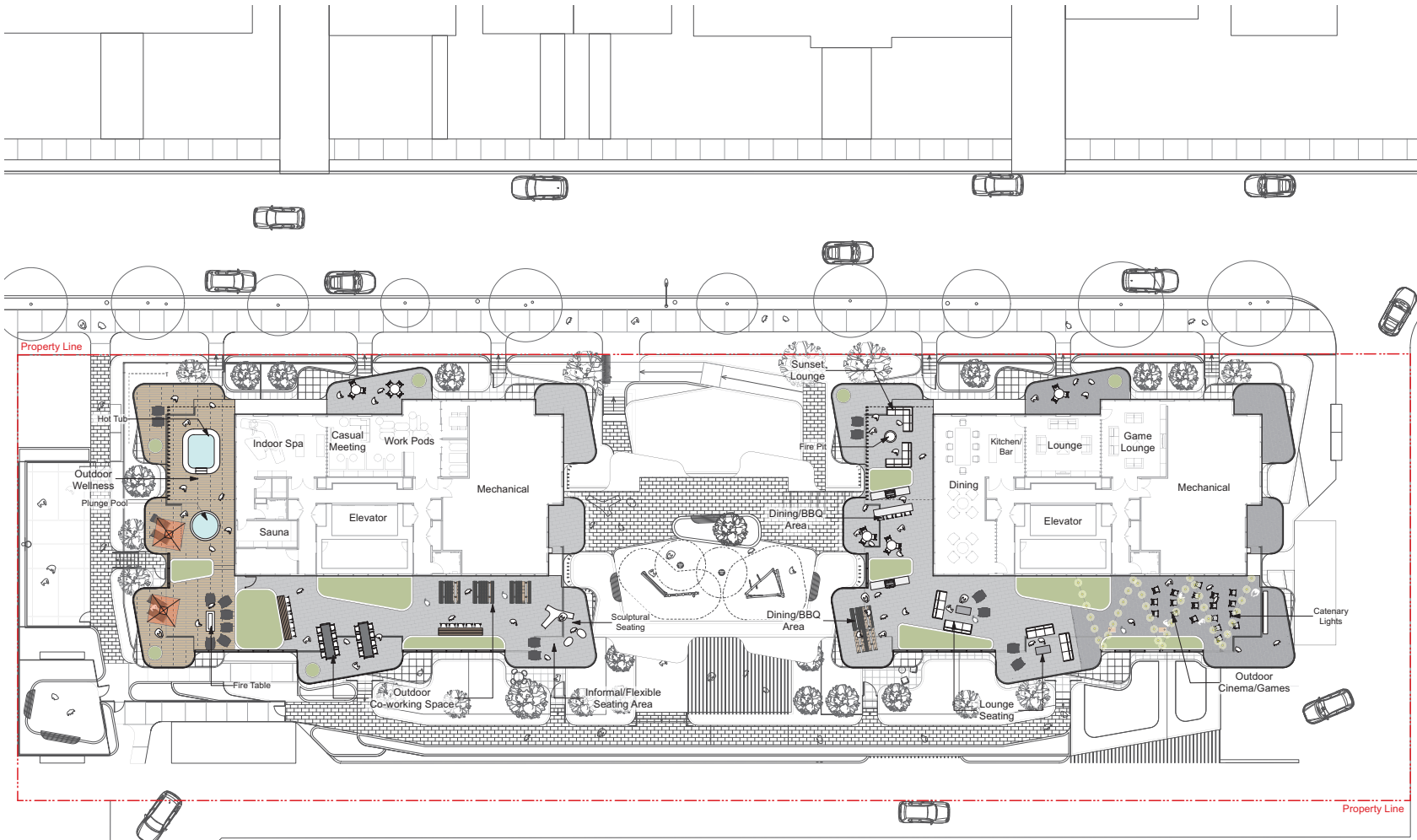

COPYRIGHT RESERVED
This drawing is and shall remain the property of Perry and Associates Inc. and Perry and Associates Inc. shall retain the copyright therein. This document shall not be reproduced or used for purposes or alterations to the project or for the purpose of any other project without the prior written consent of Perry and Associates Inc.
Client:

Project Title:
2244 - 2280 W 6th Avenue

Drawing Title:
Landscape Concept Plan L23

Project North:  Drawn By: CS
Checked By: JP
Scale: 1:50 Job No.: 24-043
Sheet No.:

L1.2



Outdoor Fitness Area



Lounge Seating



Outdoor Kitchen + Dining



Lounge Area



Dog Run



Outdoor Hot Tub



Multi Sport Court



Play Equipment



Rooftop Cinema



Unit Paving

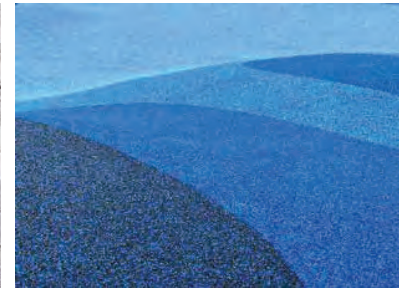

PIP Rubber Play Surface



Raised Seating Planter



Catenary Lights



Feature Planting



Urban Agriculture

P+A

Perry + Associates
Landscape Architecture
Site Planning
112 East Broadway
Vancouver, BC V5Y 1V9
T: 604.778.1118
perryandassociates.ca

Issues	Description	Date
No.		

COPYRIGHT RESERVED
This drawing is and shall remain the property of Perry and Associates Inc. and Perry and Associates Inc. shall retain the copyright therein. This document shall not be reproduced or used for purposes or alterations to the project or for the purpose of any other project without the prior written consent of Perry and Associates Inc.

Client:

Project Title:
2244 - 2280 W 6th Avenue

Drawing Title:
Landscape Precedents

Project North:	Drawn By:	CS
	Checked By:	JP
Scale:	Job No.:	20-043
Sheet No.:		

L1.3



06 ARCHITECTURAL DRAWINGS

06.5 Elevations

NORTH ELEVATION

Scale 1:400



SOUTH ELEVATION

Scale 1:400



EAST & WEST ELEVATION

Scale 1:400

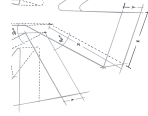
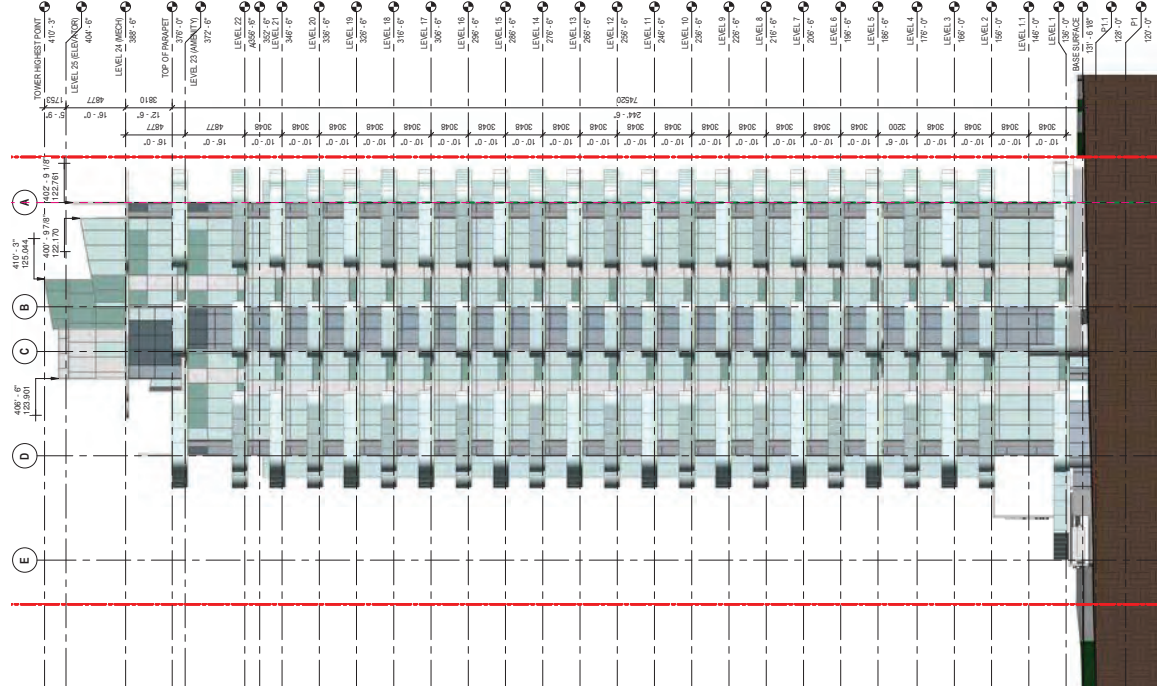
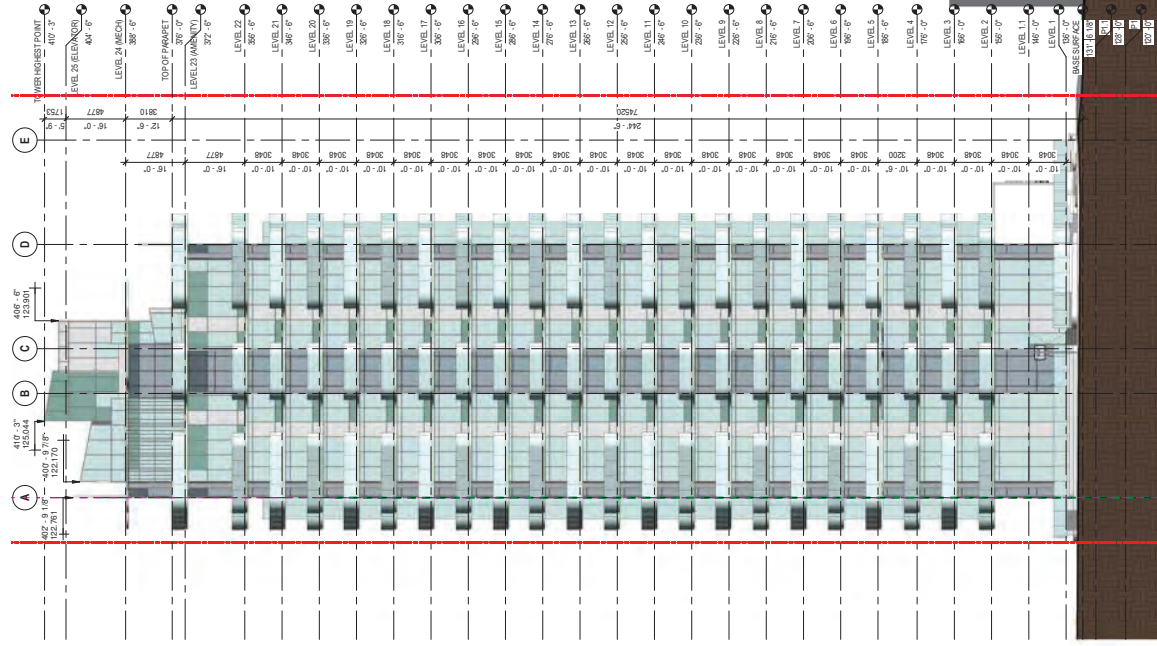



06 ARCHITECTURAL DRAWINGS

06.6 Cross - Sections

SECTIONS

Scale 1:400

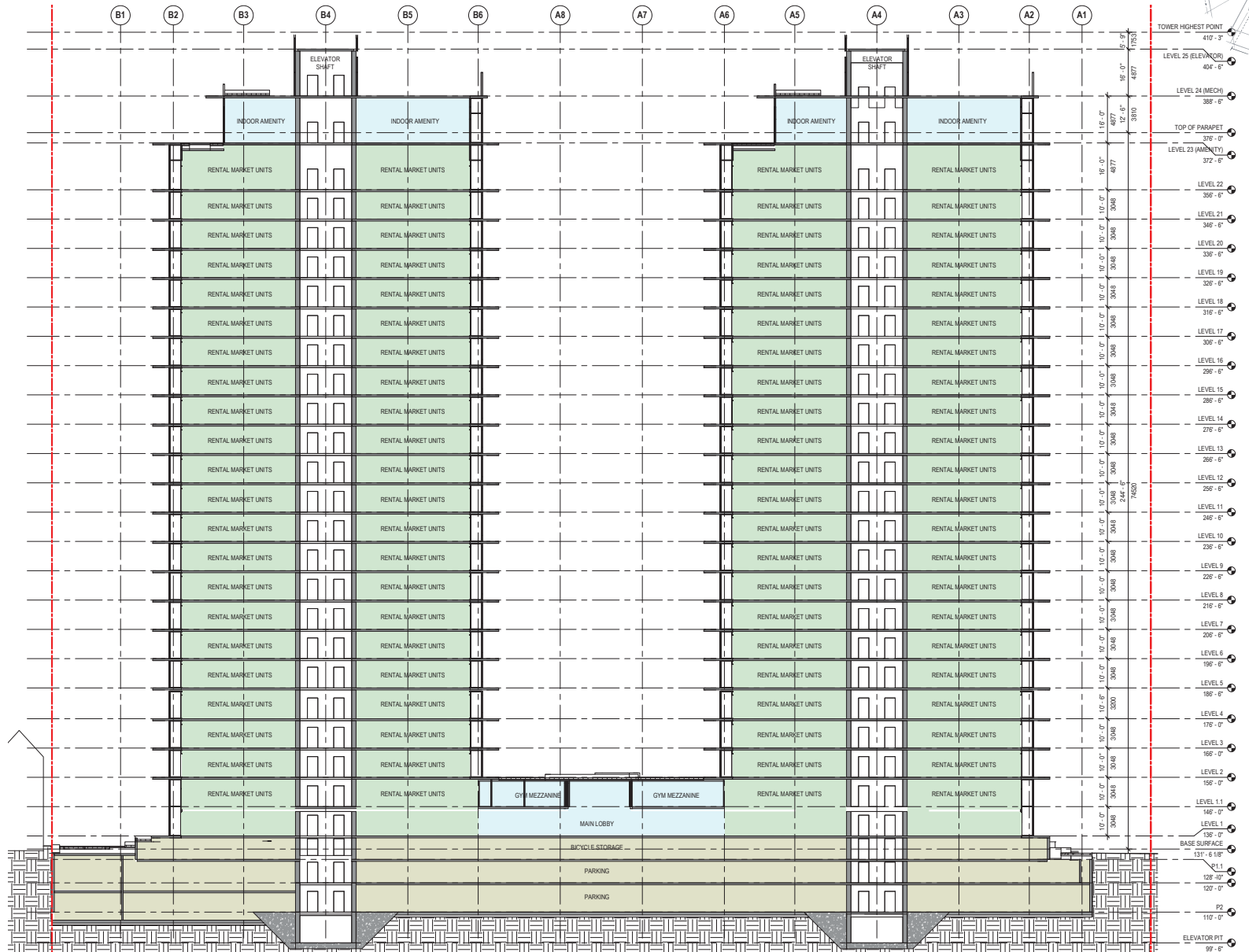

KEY PLAN

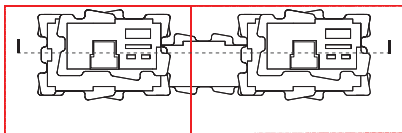



06 ARCHITECTURAL DRAWINGS

06.7 Shadow Studies

SHADOW STUDIES - SPRING EQUINOX UTC-7

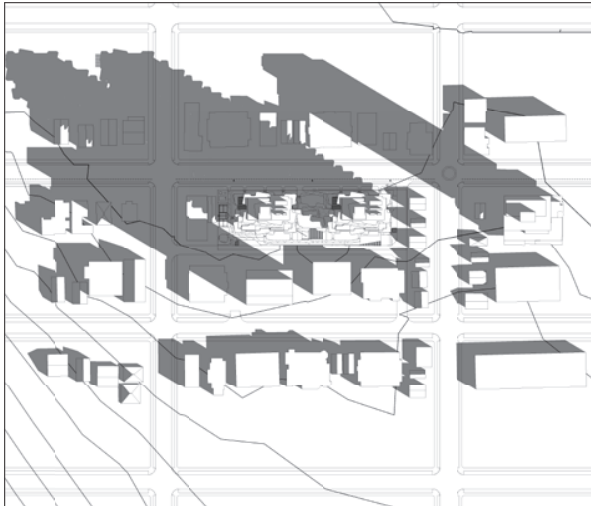
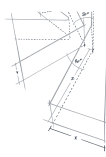

MARCH 20 - 10.00

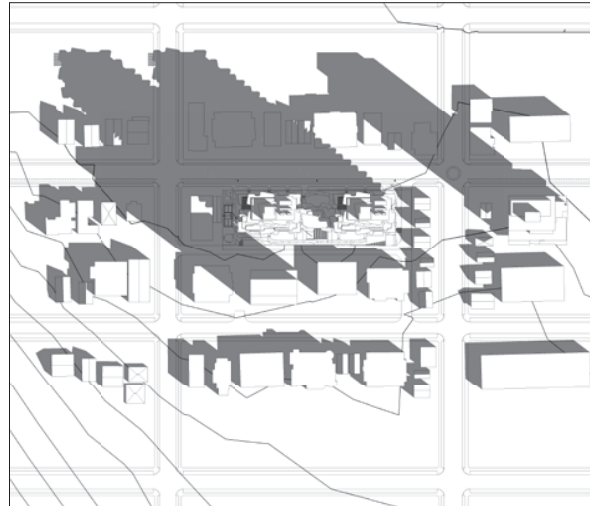

MARCH 20 - 10.20

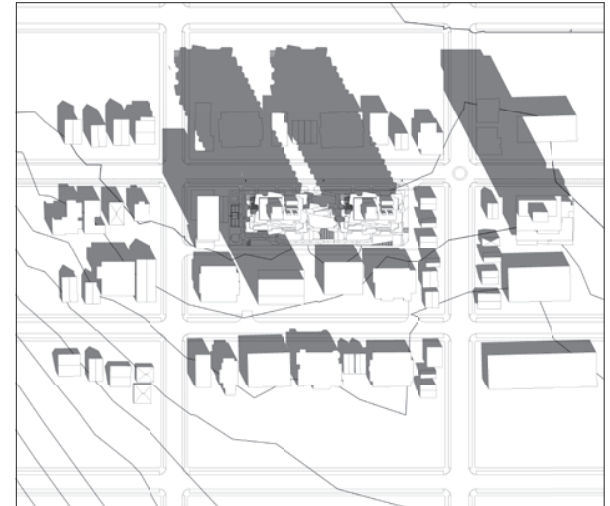

MARCH 20 - 12.00

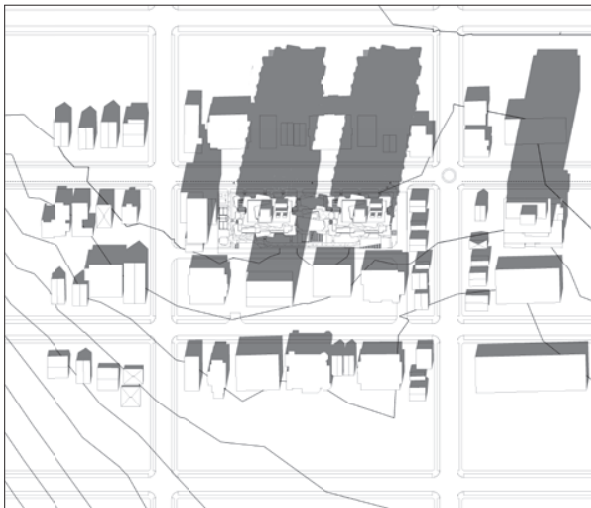

MARCH 20 - 14.00

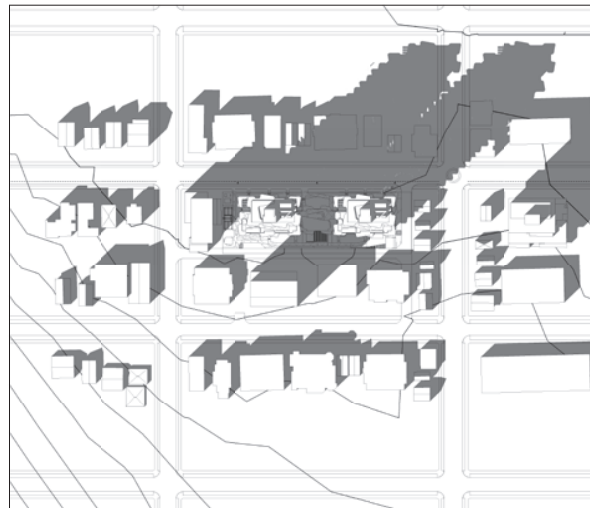

MARCH 20 - 16.00

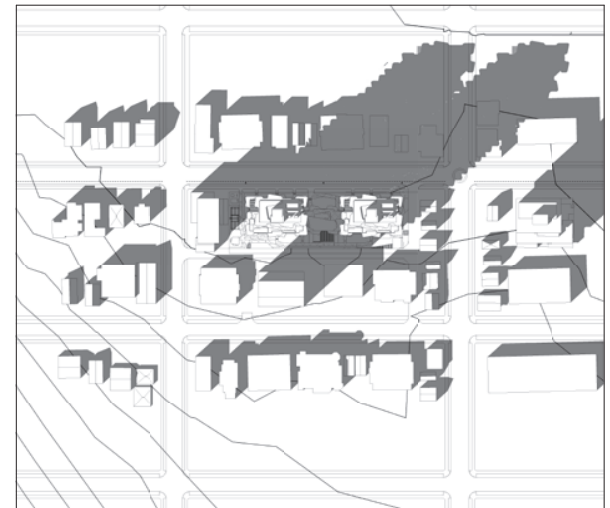

MARCH 20 - 16.05

SHADOW STUDIES - SUMMER SOLSTICE UTC-7

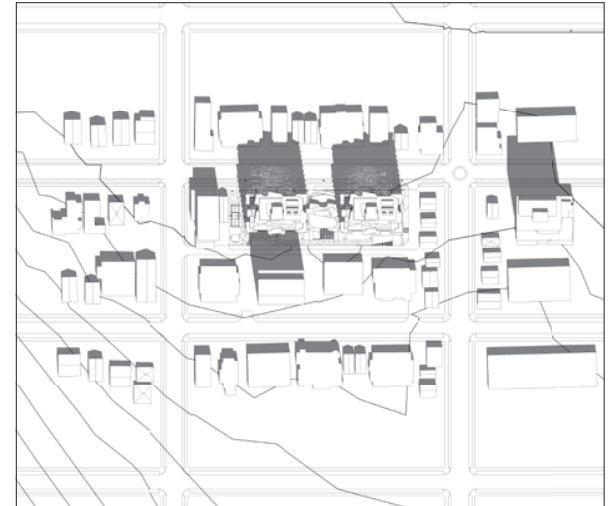
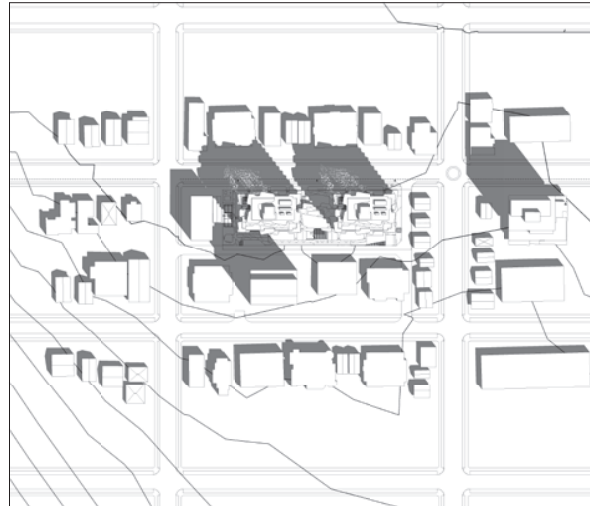
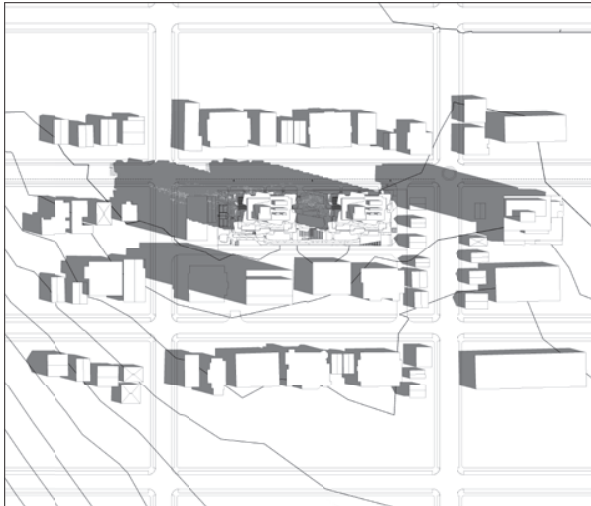
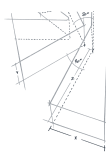

JUNE 20 - 12.00

JUNE 20 - 13.00

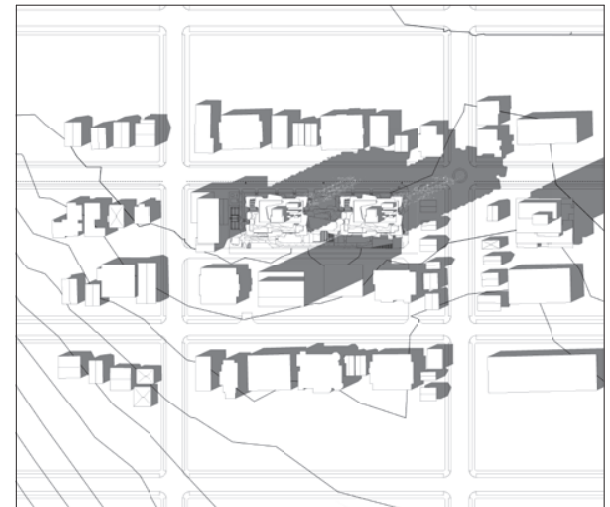

JUNE 20 - 14.00

JUNE 20 - 15.00

JUNE 20 - 16.00

SHADOW STUDIES - FALL EQUINOX UTC-7

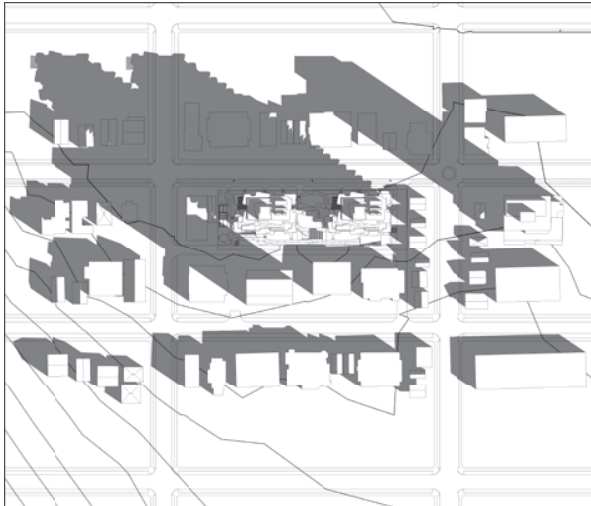

SEPTEMBER 22 - 10.00



SEPTEMBER 22 - 12.00



SEPTEMBER 22 - 13.00

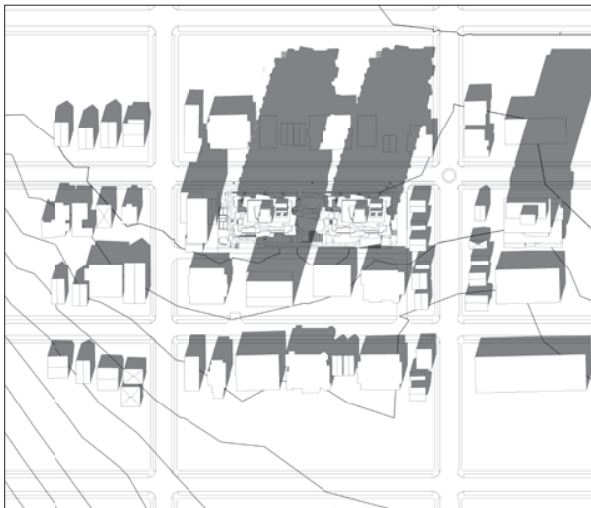

SEPTEMBER 22 - 14.00

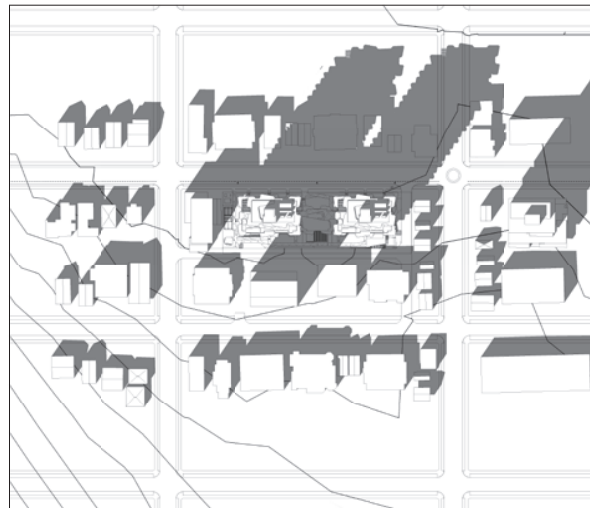

SEPTEMBER 22 - 15.00

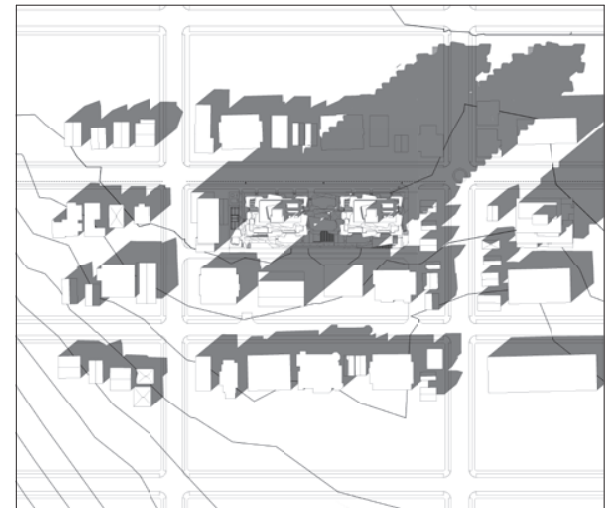

SEPTEMBER 22 - 16.00

SHADOW STUDIES - WINTER SOLSTICE

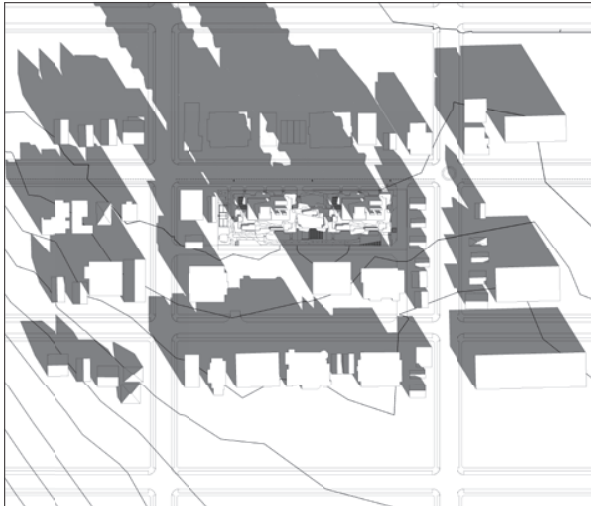
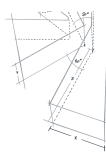

DECEMBER 22 - 10.00

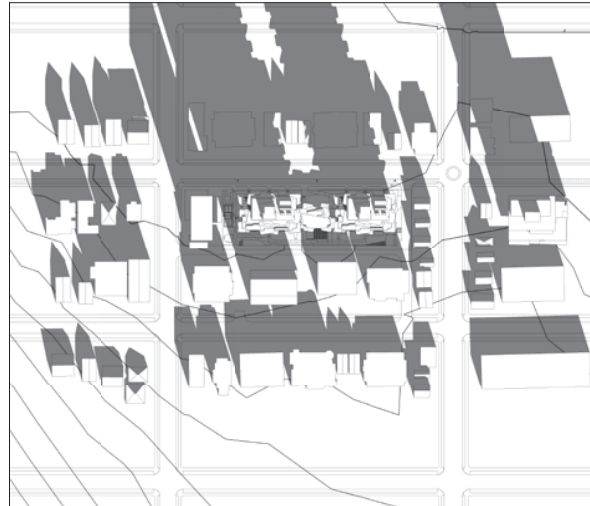

DECEMBER 22 - 12.00

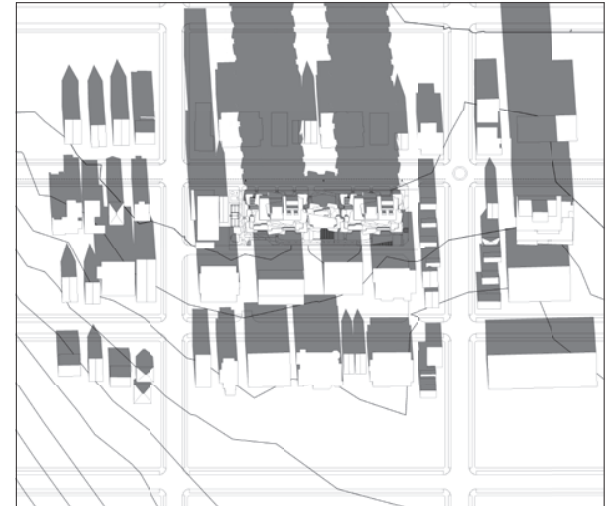

DECEMBER 22 - 13.00

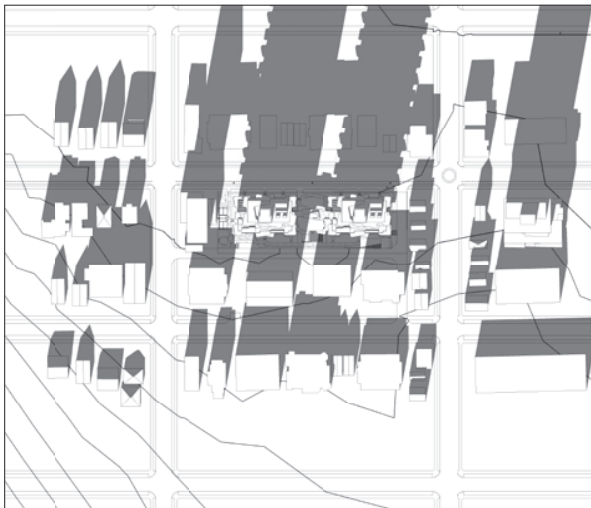

DECEMBER 22 - 14.00

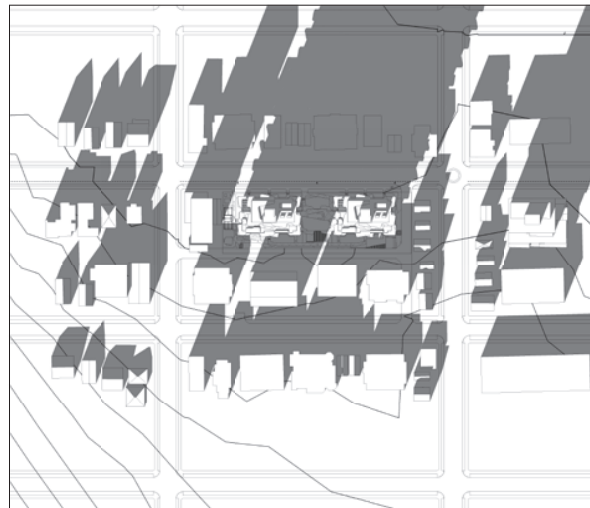

DECEMBER 22 - 15.00

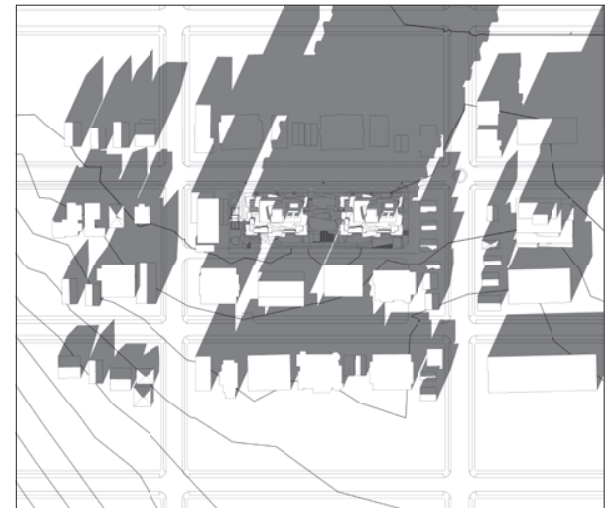

DECEMBER 22 - 16.00



06 ARCHITECTURAL DRAWINGS

06.8 Renderings

RENDERING - NORTHEAST VIEW

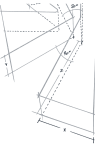

RENDERING - NORTHWEST VIEW



RENDERING - SOUTHWEST VIEW

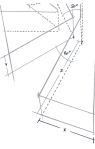

RENDERING - SOUTHEAST VIEW



RENDERING - MIDDLE BALCONY

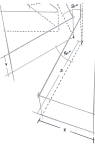

RENDERING - NORTHWEST STREET VIEW



RENDERING - NORTHEAST STREET VIEW

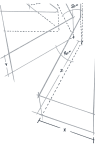

RENDERING - WEST CLASS B LOADING AND DOG RUN



RENDERING - MULTI-SPORT COURT

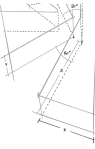

RENDERING - CHILDREN'S PLAY



RENDERING - CHILDREN'S PLAY

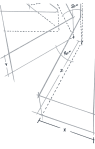

RENDERING - WEST AMENITY TOWER OUTDOOR SPA



RENDERING - WEST AMENITY TOWER OUTDOOR SPA & BBQ

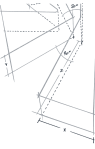

RENDERING - EAST AMENITY TOWER OUTDOOR BBQ



RENDERING - EAST AMENITY TOWER OUTDOOR BBQ

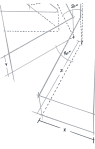



04 ARCHITECTURAL DRAWINGS

04.9 FSR Overlays

AREA PLAN P2

Scale 1:300

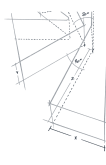

AREA SCHEDULE P2			
UNIT TYPE	DESCRIPTION	SCHEDULED AREA	COUNTABLE AREA
CAR PARKING 1	CAR PARKING	30164.37 sq'*	30164.37 sq'*
CAR PARKING 2	CAR PARKING	30164.37 sq'*	30164.37 sq'*
MEP 1	MECHANICAL	2089.68 sq'*	2089.68 sq'*
MEP 2	MECHANICAL	2089.68 sq'*	2089.68 sq'*
SERVICE 1	SERVICE	298.42 sq'*	298.42 sq'*
SERVICE 2	SERVICE	499.09 sq'*	499.09 sq'*
SERVICE 3	SERVICE	298.40 sq'*	298.40 sq'*
SERVICE 4	SERVICE	8.17 sq'*	8.17 sq'*
SERVICE 5	MEASURE N	1584.08 sq'*	1584.08 sq'*
SERVICE 6	SERVICE	527.06 sq'*	527.06 sq'*
SERVICE 7	CIRCULATION	527.06 sq'*	527.06 sq'*
SERVICE 8	SERVICE	1584.12 sq'*	1584.12 sq'*
SERVICE 9	CIRCULATION	34412.24 sq'*	34412.24 sq'*
SERVICE 10	CIRCULATION	34412.24 sq'*	34412.24 sq'*

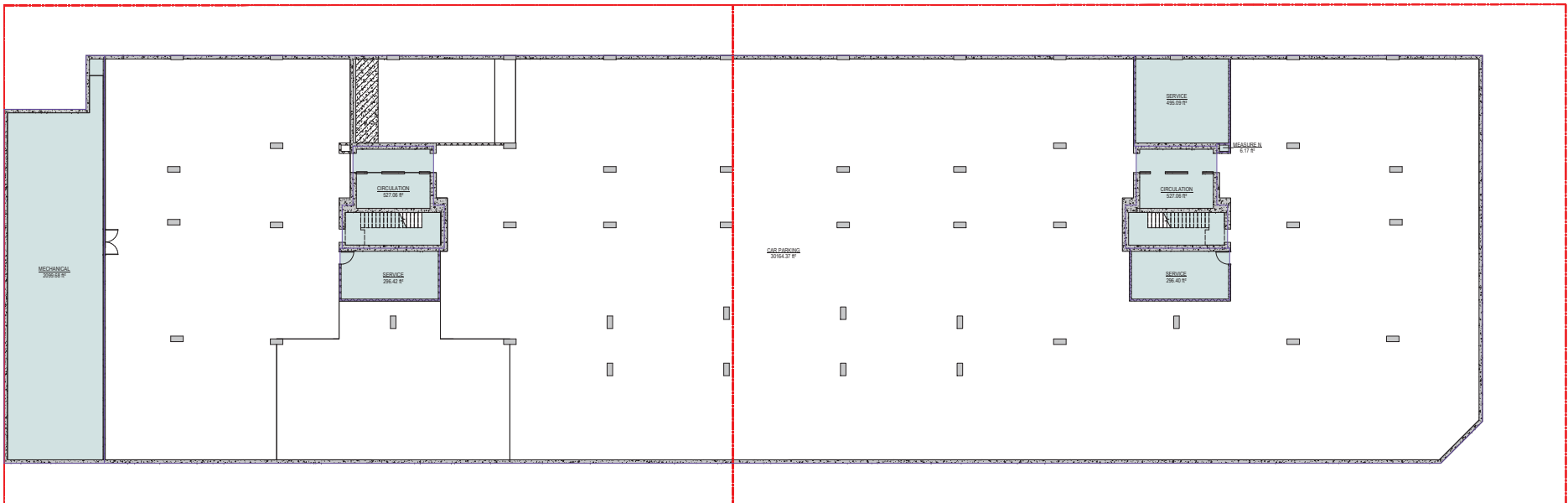

AREA PLAN P1.1

Scale 1:300

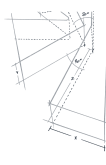

AREA SCHEDULE P1.1				
UNIT TYPE	DESCRIPTION	SCHEDULED AREA	EXEMPTION AREA	COUNTABLE AREA
PARKING BICYCLE	BICYCLE STORAGE	1903.04 SF	1903.04 SF	0.00 SF
PARKING BICYCLE	BICYCLE STORAGE	333.32 SF	333.32 SF	0.00 SF
PARKING BICYCLE	CLASS B BICYCLE & BICYCLE REPAIR / TOOL LENDING LIBRARY	542.80 SF	542.80 SF	0.00 SF
SERVICE	RECYCLING	549.04 SF	549.04 SF	0.00 SF
SERVICE	RECYCLING	599.02 SF	599.02 SF	0.00 SF
SERVICE	BIKE / PET WASH	80.71 SF	80.71 SF	0.00 SF
SERVICE	BIKE / PET WASH	120.91 SF	120.91 SF	0.00 SF
SERVICE	SNOWBOARD / SKI WAXING	527.06 SF	527.06 SF	0.00 SF
SERVICE	CIRCULATION	527.06 SF	527.06 SF	0.00 SF
SERVICE	CIRCULATION	527.06 SF	527.06 SF	0.00 SF
SERVICE	CIRCULATION	307.51 SF	307.51 SF	0.00 SF
SERVICE	CIRCULATION	185.39 SF	185.39 SF	0.00 SF
SERVICE	CIRCULATION	478.08 SF	478.08 SF	0.00 SF
SERVICE	CIRCULATION	137.20 SF	137.20 SF	0.00 SF
SERVICE	CIRCULATION	70.07 SF	70.07 SF	0.00 SF
SERVICE: M		2426.78 SF	2426.78 SF	-0.01 SF
		2426.78 SF	2426.78 SF	-0.01 SF

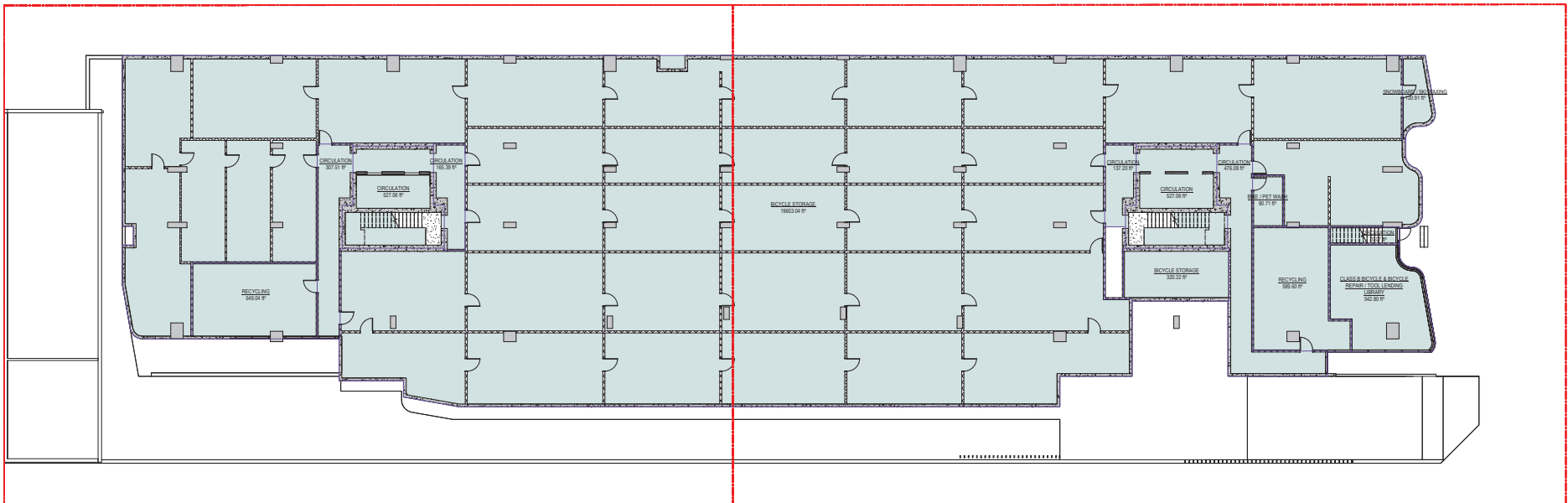

AREA PLAN L1.1

Scale 1:300

AREA SCHEDULE L1.1				
UNIT TYPE	DESCRIPTION	BUILDABLE AREA	EXEMPTION AREA	COUNTABLE AREA
LAI	W103 UPPER	133.21 m ²	0.00 m ²	133.21 m ²
LAI	E103 UPPER	133.21 m ²	0.00 m ²	133.21 m ²
LAI.2		356.63 m ²	0.00 m ²	356.63 m ²
LB1.1	W101 UPPER	236.63 m ²	0.00 m ²	236.63 m ²
LB1.1	E101 UPPER	236.63 m ²	0.00 m ²	236.63 m ²
LB1.1.2		473.27 m ²	0.00 m ²	473.27 m ²
LB1.2	W105 UPPER	228.23 m ²	0.00 m ²	228.23 m ²
LB1.2	E105 UPPER	228.23 m ²	0.00 m ²	228.23 m ²
LB1.2.2		456.46 m ²	0.00 m ²	456.46 m ²
LB2	W102 UPPER	299.61 m ²	0.00 m ²	299.61 m ²
LB2	E102 UPPER	299.61 m ²	0.00 m ²	299.61 m ²
LB2.2		599.22 m ²	0.00 m ²	599.22 m ²
LB3.1	W106 UPPER	234.22 m ²	0.00 m ²	234.22 m ²
LB3.1	E106 UPPER	234.22 m ²	0.00 m ²	234.22 m ²
LB3.1.2		468.44 m ²	0.00 m ²	468.44 m ²
LB3.2	W112 UPPER	239.89 m ²	0.00 m ²	239.89 m ²
LB3.2	E112 UPPER	239.89 m ²	0.00 m ²	239.89 m ²
LB3.2.2		479.78 m ²	0.00 m ²	479.78 m ²
LB4	W111 UPPER	302.60 m ²	0.00 m ²	302.60 m ²
LB4	E111 UPPER	302.60 m ²	0.00 m ²	302.60 m ²
LB4.1		302.60 m ²	0.00 m ²	302.60 m ²
LB4.1.2		605.21 m ²	0.00 m ²	605.21 m ²
LB4.2	W107 UPPER	302.60 m ²	0.00 m ²	302.60 m ²
LB4.2	E107 UPPER	302.60 m ²	0.00 m ²	302.60 m ²
LB4.2.2		605.21 m ²	0.00 m ²	605.21 m ²
LC1	W104 UPPER	264.37 m ²	0.00 m ²	264.37 m ²
LC1	E104 UPPER	264.37 m ²	0.00 m ²	264.37 m ²
LC1.2		528.74 m ²	0.00 m ²	528.74 m ²
UNIT: 18		4882.74 m ²	0.00 m ²	4882.74 m ²

AREA SCHEDULE L1.1				
UNIT TYPE	DESCRIPTION	BUILDABLE AREA	EXEMPTION AREA	COUNTABLE AREA
AMENITY	CIRCULATION	524.69 m ²	524.69 m ²	0.00 m ²
AMENITY	CIRCULATION	407.76 m ²	407.76 m ²	0.00 m ²
AMENITY	CIRCULATION	130.72 m ²	130.72 m ²	0.00 m ²
AMENITY CIRCULATION 3		1052.57 m ²	1052.57 m ²	0.00 m ²
INDOOR AMENITY	MANAGER OFFICE	165.24 m ²	165.24 m ²	0.00 m ²
INDOOR AMENITY	GYM MEZZANINE	1128.89 m ²	1128.89 m ²	0.00 m ²
INDOOR AMENITY	LEASING	44.51 m ²	44.51 m ²	0.01 m ²
INDOOR AMENITY	WASHROOM	133.64 m ²	133.64 m ²	0.01 m ²
INDOOR AMENITY		2391.21 m ²	2391.21 m ²	0.01 m ²
INDOOR AMENITY		6973.96 m ²	2391.21 m ²	4882.75 m ²

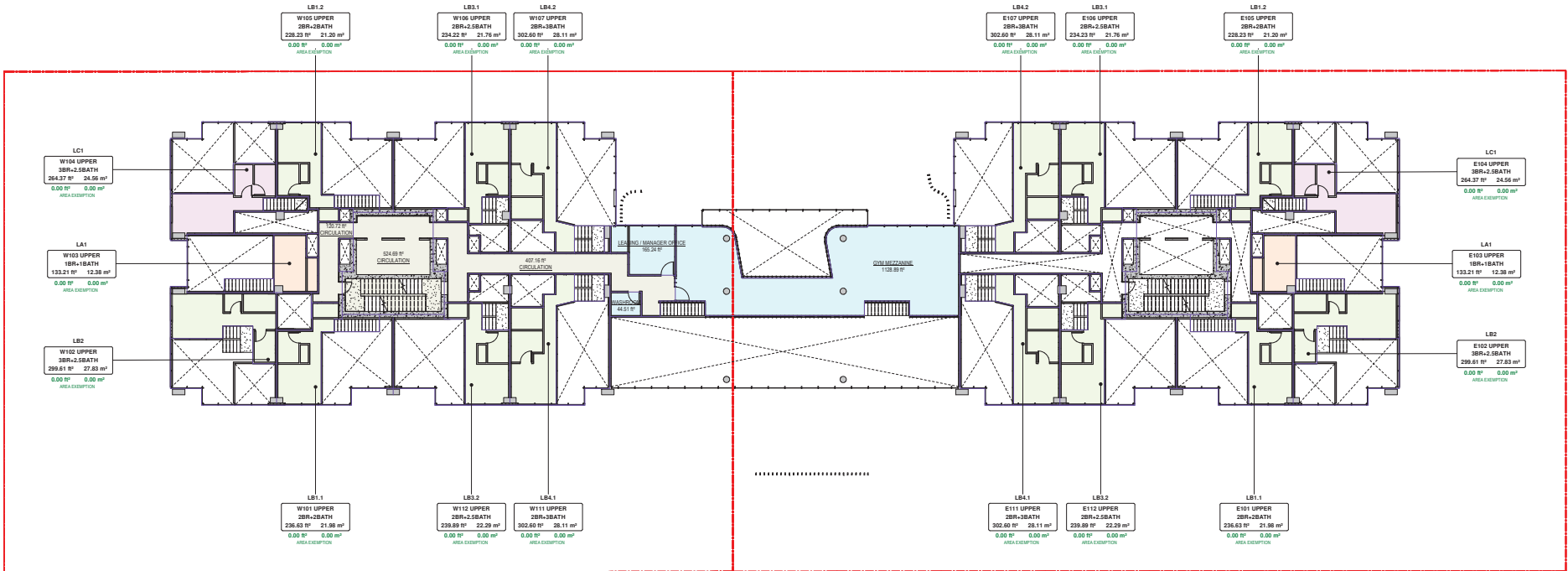

AREA PLAN P13-22

Scale 1:300

AREA SCHEDULE L13-22					AREA SCHEDULE L13-22					AREA SCHEDULE L13-22				
UNIT TYPE	DESCRIPTION	BUILDABLE AREA	EXEMPTION AREA	COUNTABLE AREA	UNIT TYPE	DESCRIPTION	BUILDABLE AREA	EXEMPTION AREA	COUNTABLE AREA	UNIT TYPE	DESCRIPTION	BUILDABLE AREA	EXEMPTION AREA	COUNTABLE AREA
A1.1	W1305-2205	530.54 m ²	40.00 m ²	490.54 m ²	MEP	MEP	16.32 m ²	0.00 m ²	16.32 m ²	A1.1	BALCONY	188.67 m ²		
A1.1	W1306-2206	530.23 m ²	40.00 m ²	490.23 m ²	MEP	MEP	26.98 m ²	0.00 m ²	26.98 m ²	A1.1	BALCONY	87.55 m ²		
A1.1	E1305-2205	530.23 m ²	40.00 m ²	490.23 m ²	MEP	MEP	11.59 m ²	0.00 m ²	11.59 m ²	A1.1	BALCONY	87.55 m ²		
A1.4	W1301-2201	2121.54 m ²	160.00 m ²	1961.54 m ²	MEP	MEP	26.78 m ²	0.00 m ²	26.78 m ²	A1.4	BALCONY	188.67 m ²	0.00 m ²	0.00 m ²
A1.2	W1302-2202	532.80 m ²	40.00 m ²	492.80 m ²	MEP	MEP	26.78 m ²	0.00 m ²	26.78 m ²	A1.2	BALCONY	188.67 m ²		
A1.2	E1301-2201	533.10 m ²	40.00 m ²	493.10 m ²	MEP	MEP	16.32 m ²	0.00 m ²	16.32 m ²	A1.2	BALCONY	87.55 m ²		
A1.2	E1302-2202	532.80 m ²	40.00 m ²	492.80 m ²	MEP	MEP	26.98 m ²	0.00 m ²	26.98 m ²	A1.2	BALCONY	87.55 m ²		
A1.2	W1303-2203	2131.80 m ²	160.00 m ²	1971.80 m ²	MEP	MEP	11.59 m ²	0.00 m ²	11.59 m ²	A1.2	BALCONY	188.67 m ²	0.00 m ²	0.00 m ²
B1	W1304-2204	747.80 m ²	40.00 m ²	707.80 m ²	MEP	MEP	26.78 m ²	0.00 m ²	26.78 m ²	A1.2	STUDIO	152.44 m ²	0.00 m ²	0.00 m ²
B1	W1302-2202	747.80 m ²	40.00 m ²	707.80 m ²	MEP	MEP	11.59 m ²	0.00 m ²	11.59 m ²	B1	BALCONY	241.43 m ²		
B1	E1304-2204	747.80 m ²	40.00 m ²	707.80 m ²	MEP	MEP	26.78 m ²	0.00 m ²	26.78 m ²	B1	BALCONY	241.43 m ²		
B1	E1302-2202	747.80 m ²	40.00 m ²	707.80 m ²	MEP	MEP	11.59 m ²	0.00 m ²	11.59 m ²	B1	BALCONY	241.43 m ²		
B1.4		2889.48 m ²	160.00 m ²	2829.48 m ²	RESIDENTIAL CIRCULATION	CIRCULATION	153.67 m ²	0.00 m ²	153.67 m ²	B1.4	BALCONY	899.48 m ²	0.00 m ²	0.00 m ²
CL1	W1307-2207	933.34 m ²	40.00 m ²	893.34 m ²	RESIDENTIAL CIRCULATION	CIRCULATION	163.31 m ²	0.00 m ²	163.31 m ²	CL1	BALCONY	241.43 m ²		
CL1	E1307-2207	933.34 m ²	40.00 m ²	893.34 m ²	RESIDENTIAL CIRCULATION	CIRCULATION	11.91 m ²	0.00 m ²	11.91 m ²	CL1	BALCONY	80.42 m ²		
CL1.2		1868.68 m ²	80.00 m ²	1788.68 m ²	RESIDENTIAL CIRCULATION	CIRCULATION	524.68 m ²	0.00 m ²	524.68 m ²	CL1	BALCONY	288.31 m ²		
CL1.2	W1308-2208	453.06 m ²	40.00 m ²	413.06 m ²	RESIDENTIAL CIRCULATION	CIRCULATION	153.67 m ²	0.00 m ²	153.67 m ²	CL1	BALCONY	80.42 m ²		
CL1.2	E1308-2208	503.06 m ²	40.00 m ²	463.06 m ²	RESIDENTIAL CIRCULATION	CIRCULATION	163.31 m ²	0.00 m ²	163.31 m ²	CL1.2	BALCONY	80.42 m ²		
CL1.2	W1309-2209	1936.12 m ²	80.00 m ²	1856.12 m ²	RESIDENTIAL CIRCULATION	CIRCULATION	163.31 m ²	0.00 m ²	163.31 m ²	CL1.2	BALCONY	80.42 m ²		
CL1.2	E1309-2209	425.31 m ²	35.00 m ²	390.31 m ²	RESIDENTIAL CIRCULATION	CIRCULATION	524.68 m ²	0.00 m ²	524.68 m ²	CL1.2	STUDIO	152.44 m ²	0.00 m ²	0.00 m ²
S1	W1303-2203	425.31 m ²	35.00 m ²	390.31 m ²	RESIDENTIAL CIRCULATION	CIRCULATION	1723.35 m ²	0.00 m ²	1723.35 m ²	S1	BALCONY	120.51 m ²		
S1	E1303-2203	425.31 m ²	35.00 m ²	390.31 m ²	COMMON	COMMON	1949.75 m ²	0.00 m ²	1949.75 m ²	S1	BALCONY	241.43 m ²	0.00 m ²	0.00 m ²
S1.2		160.00 m ²	70.00 m ²	90.00 m ²	COMMON	COMMON	1307.47 m ²	0.00 m ²	1307.47 m ²	S1.2	BALCONY	241.43 m ²	0.00 m ²	0.00 m ²
UNIT 18		1196.62 m ²	710.00 m ²	486.62 m ²	COMMON	COMMON	1307.47 m ²	0.00 m ²	1307.47 m ²	S1.2	BALCONY	241.43 m ²	0.00 m ²	0.00 m ²
					Gross Building Area 36		1307.47 m ²	0.00 m ²	1307.47 m ²	Exterior Area 22		17123.40 m ²	710.00 m ²	13105.99 m ²

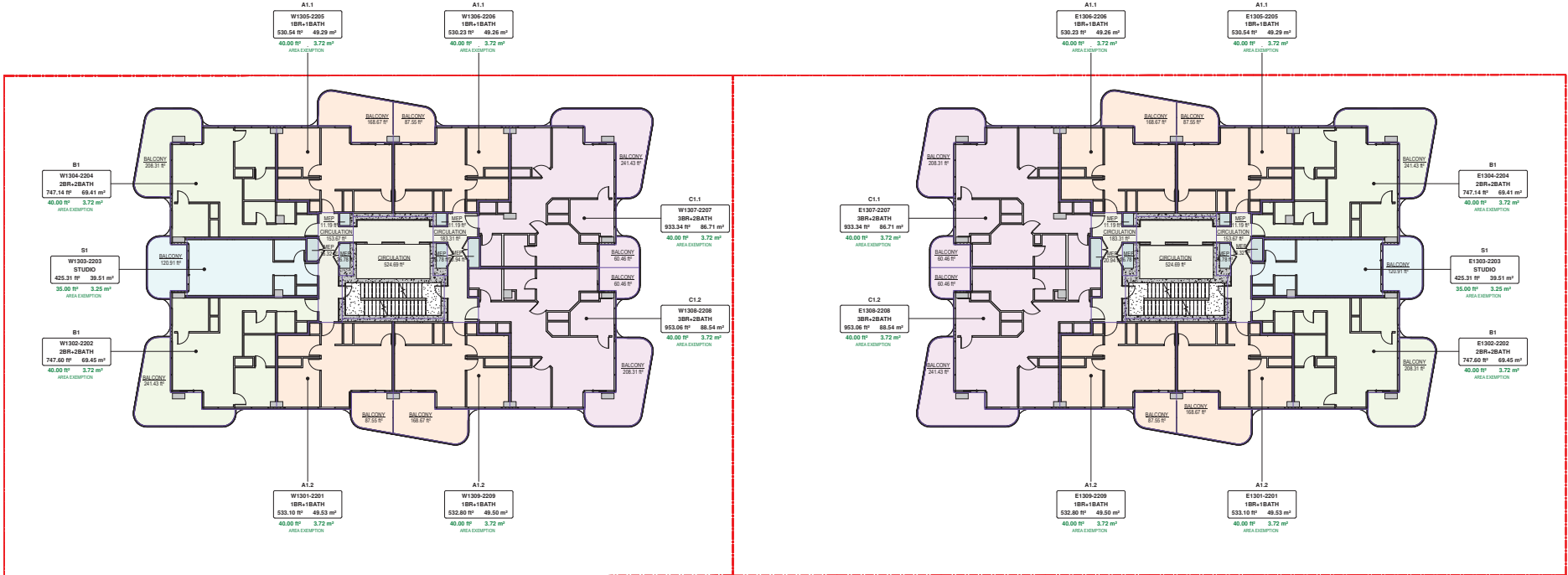

AREA PLAN P23

Scale 1:300

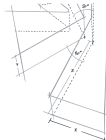

AREA SCHEDULE L13				
UNIT TYPE	DESCRIPTION	BUILDABLE AREA	EXEMPTION AREA	COUNTABLE AREA
MEP CIRCULATION	MEP CIRCULATION	277.66 ft²	277.66 ft²	0.00 ft²
MEP CIRCULATION	MEP CIRCULATION	277.66 ft²	277.66 ft²	0.00 ft²
MEP CIRCULATION	MEP CIRCULATION	171.25 ft²	171.25 ft²	0.00 ft²
MEP CIRCULATION	MEP CIRCULATION	171.25 ft²	171.25 ft²	0.00 ft²
MEP CIRCULATION 4		897.82 ft²	897.82 ft²	0.00 ft²
MEP CLOSET	MEP	16.32 ft²	16.32 ft²	0.00 ft²
MEP CLOSET	MEP	16.32 ft²	16.32 ft²	0.00 ft²
MEP CLOSET	MEP	9.97 ft²	9.97 ft²	0.00 ft²
MEP CLOSET	MEP	26.78 ft²	26.78 ft²	0.00 ft²
MEP CLOSET	MEP	16.32 ft²	16.32 ft²	0.00 ft²
MEP CLOSET	MEP	16.32 ft²	16.32 ft²	0.00 ft²
MEP CLOSET	MEP	9.97 ft²	9.97 ft²	0.00 ft²
MEP CLOSET	MEP	16.78 ft²	16.78 ft²	0.00 ft²
MEP CLOSET	MEP	16.32 ft²	16.32 ft²	0.00 ft²
MEP CLOSET	MEP	16.32 ft²	16.32 ft²	0.00 ft²
MEP CLOSET	MEP	9.97 ft²	9.97 ft²	0.00 ft²
MEP CLOSET	MEP	26.78 ft²	26.78 ft²	0.00 ft²
MEP CLOSET	MEP	9.97 ft²	9.97 ft²	0.00 ft²
MEP CLOSET	MEP	26.78 ft²	26.78 ft²	0.00 ft²
MEP CLOSET 12		212.28 ft²	212.28 ft²	0.00 ft²
MEP ROOM	MECHANICAL ROOM	1260.81 ft²	1260.81 ft²	0.00 ft²
MEP ROOM 2	MECHANICAL ROOM	2621.63 ft²	2621.62 ft²	0.01 ft²
SERVICE 18		3631.73 ft²	3631.72 ft²	0.01 ft²

AREA SCHEDULE L13				
UNIT TYPE	DESCRIPTION	BUILDABLE AREA	EXEMPTION AREA	COUNTABLE AREA
AMENITY CIRCULATION	AMENITY CIRCULATION	171.25 ft²	171.25 ft²	0.00 ft²
AMENITY CIRCULATION	AMENITY CIRCULATION	171.25 ft²	171.25 ft²	0.00 ft²
AMENITY CIRCULATION	AMENITY CIRCULATION	277.66 ft²	277.66 ft²	0.00 ft²
AMENITY CIRCULATION	AMENITY CIRCULATION	277.66 ft²	277.66 ft²	0.00 ft²
AMENITY CIRCULATION 4		897.82 ft²	897.82 ft²	0.00 ft²
INDOOR AMENITY	JANITOR	23.07 ft²	23.07 ft²	0.00 ft²
INDOOR AMENITY	INDOOR SPA	840.50 ft²	840.50 ft²	0.00 ft²
INDOOR AMENITY	CO-WORKING	735.78 ft²	735.78 ft²	0.00 ft²
INDOOR AMENITY	DINING	840.50 ft²	840.50 ft²	0.00 ft²
INDOOR AMENITY	LOUNGE	735.78 ft²	735.78 ft²	0.00 ft²
INDOOR AMENITY	UNIVERSAL BATHROOM	53.62 ft²	53.62 ft²	0.00 ft²
INDOOR AMENITY	UNIVERSAL BATHROOM	53.62 ft²	53.62 ft²	0.00 ft²
INDOOR AMENITY	JANITOR	23.07 ft²	23.07 ft²	0.00 ft²
INDOOR AMENITY 8		3395.95 ft²	3395.94 ft²	0.01 ft²
INDOOR AMENITY 12		4203.77 ft²	4203.76 ft²	0.01 ft²
Grass Building Area 30		7835.50 ft²	7835.48 ft²	0.02 ft²

AREA SCHEDULE L13				
UNIT TYPE	DESCRIPTION	BUILDABLE AREA	EXEMPTION AREA	COUNTABLE AREA
OUTDOOR AMENITY	OUTDOOR AMENITY	426.19 ft²		
OUTDOOR AMENITY	OUTDOOR AMENITY	426.19 ft²		
OUTDOOR AMENITY 2		8402.38 ft²	0.00 ft²	0.00 ft²
Outdoor Area 2		8402.38 ft²	0.00 ft²	0.00 ft²
		10287.88 ft²	7835.48 ft²	0.02 ft²

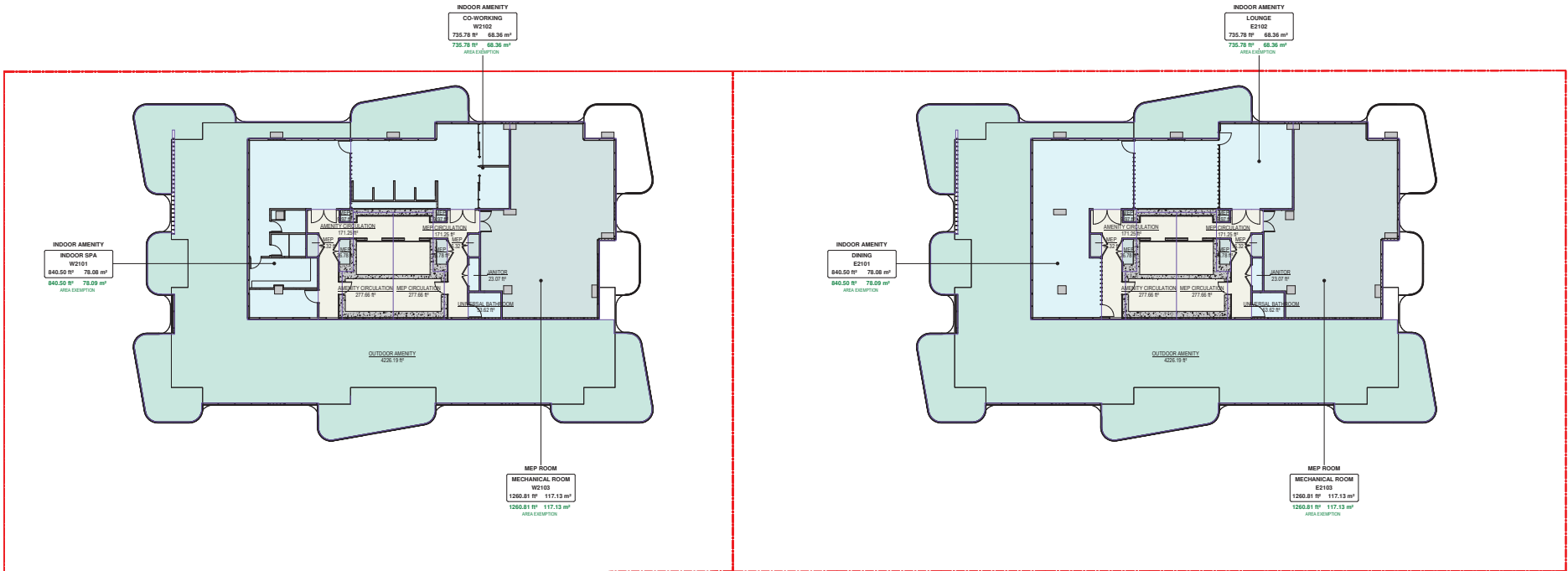

AREA PLAN L24

Scale 1:300

AREA SCHEDULE L24				
UNIT TYPE	DESCRIPTION	SCHEDULE AREA	EXEMPTION AREA	COUNTABLE AREA
MEP	ELEVATOR MACHINE ROOM	608.78 sq'	608.78 sq'	0.00 sq'
MEP	ELEVATOR MACHINE ROOM	608.78 sq'	608.78 sq'	0.00 sq'
MEP-2		1317.56 sq'	1317.56 sq'	0.00 sq'
SERVICE 2		1317.56 sq'	1317.56 sq'	0.00 sq'
Building Common Area 2		1317.56 sq'	1317.56 sq'	0.00 sq'

